

SeceuroGlide Sectional Fitting Instructions

Fitter's Information Pack – SeceuroGlide Sectional Elite

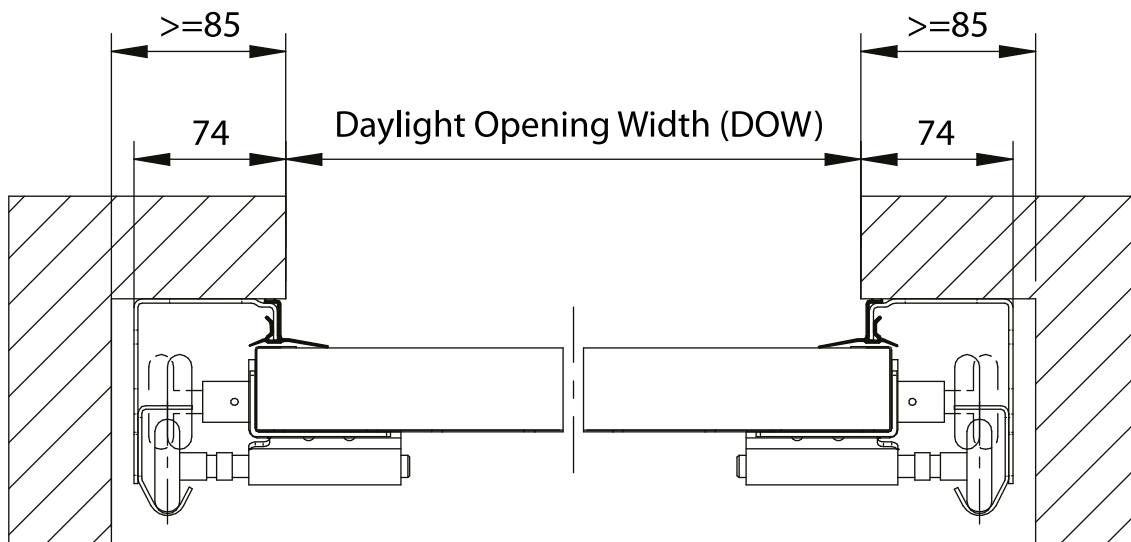

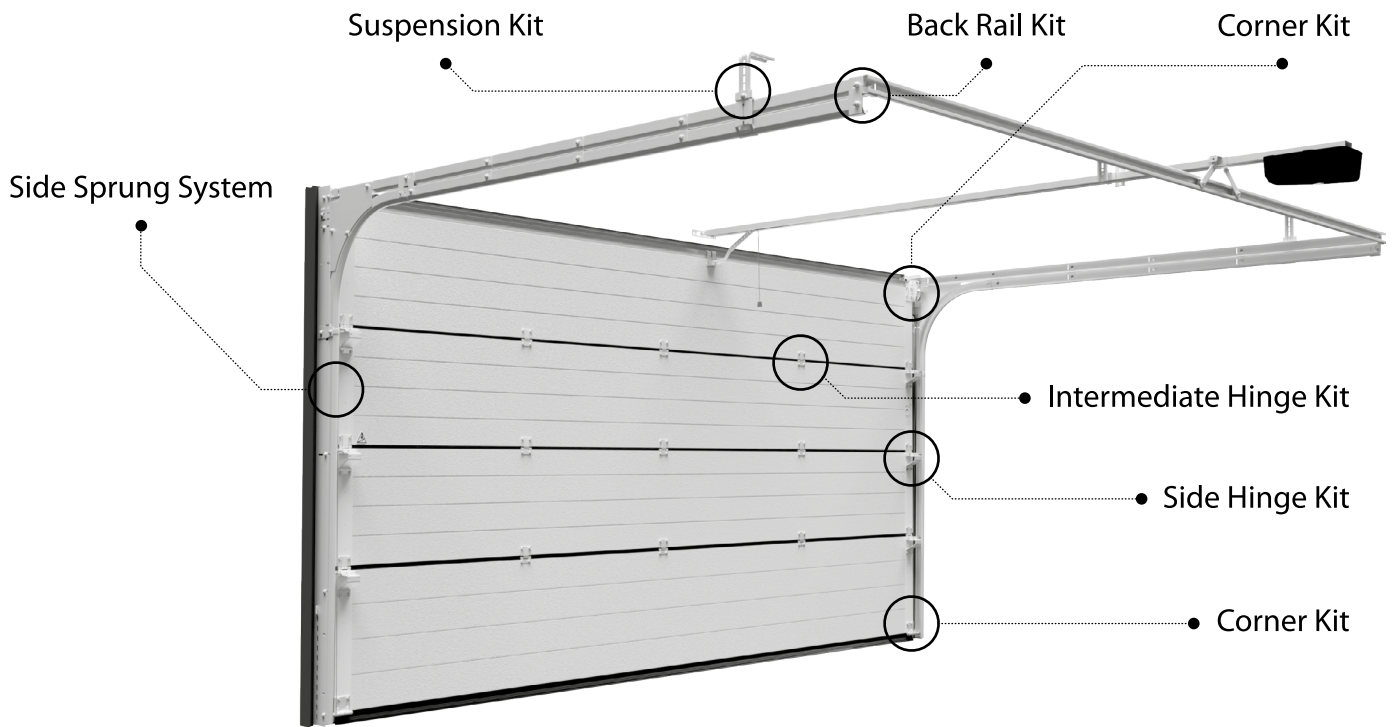
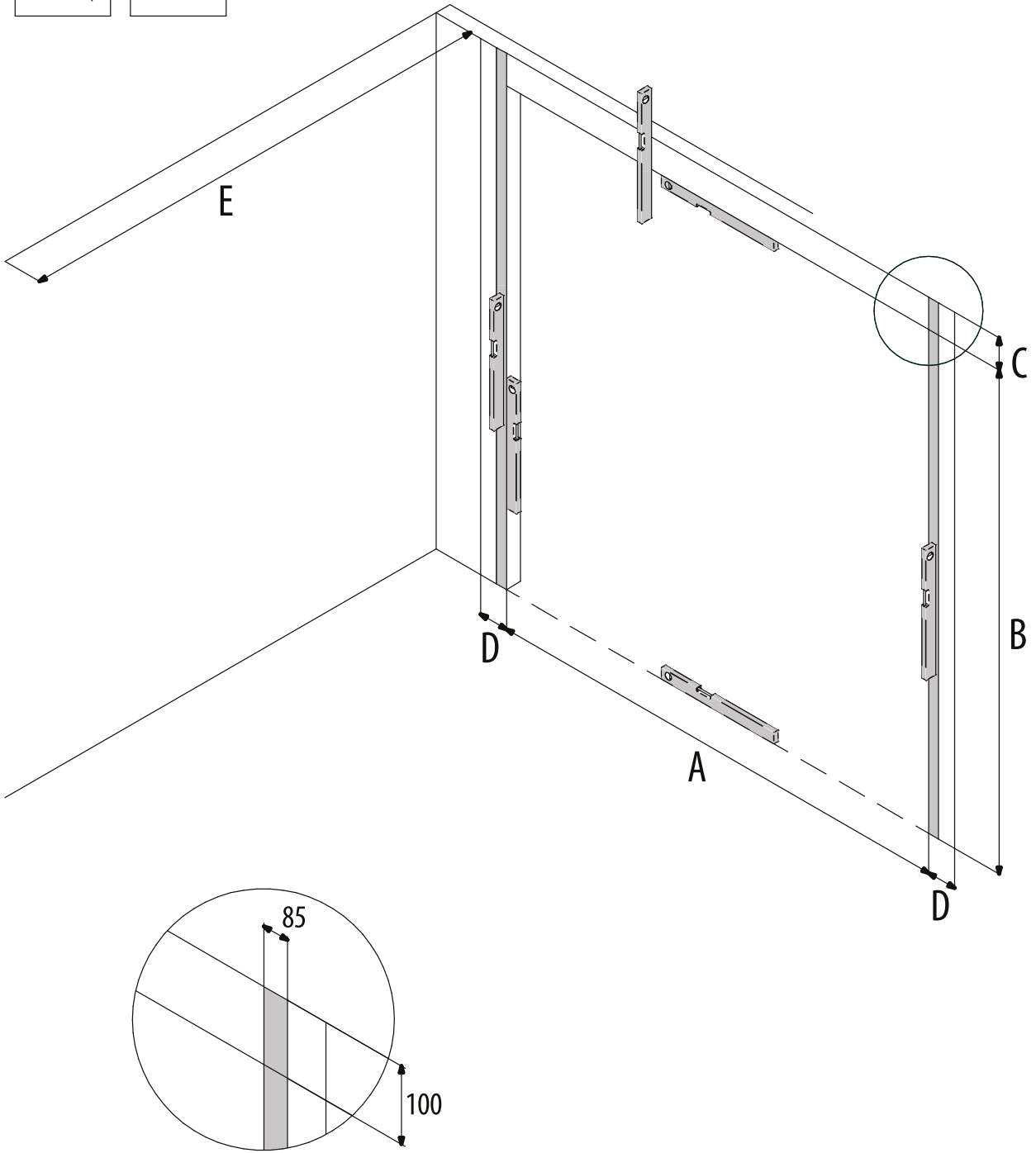
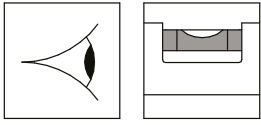

A	B	C	D	E
DLW	DLH	FLW	FSR	FMD
Daylight Width	Daylight Height	Free Head Room	Free Side Room	Free Mounting Dept

Reveal Fix - Executive Framing Kit Option

For Face Fix instructions, see page 7

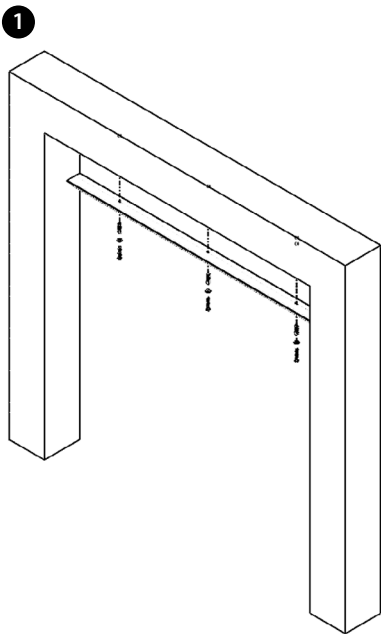
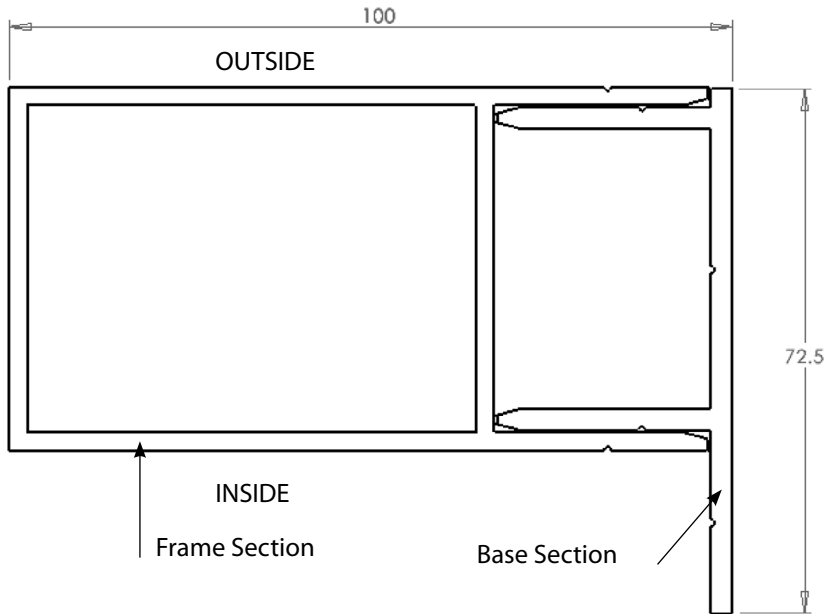

Fit horizontal base section. Ensure square and level. Secure with fixings from **Kit 023**.

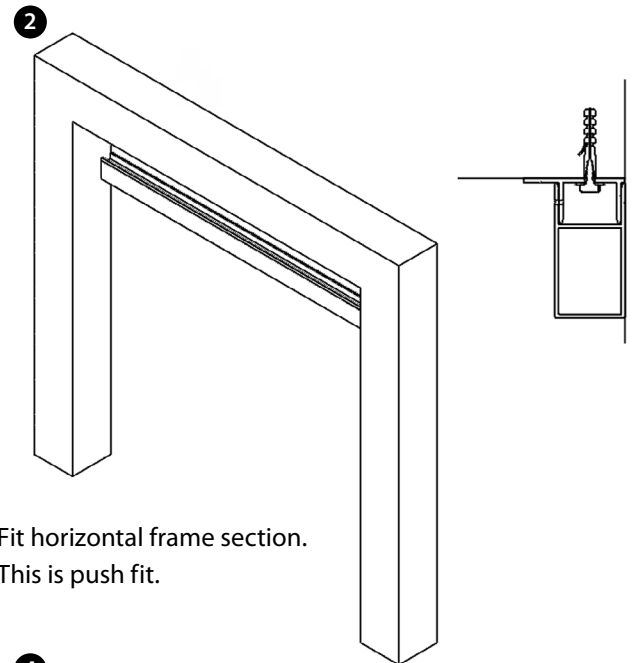

Fit horizontal frame section. This is push fit.

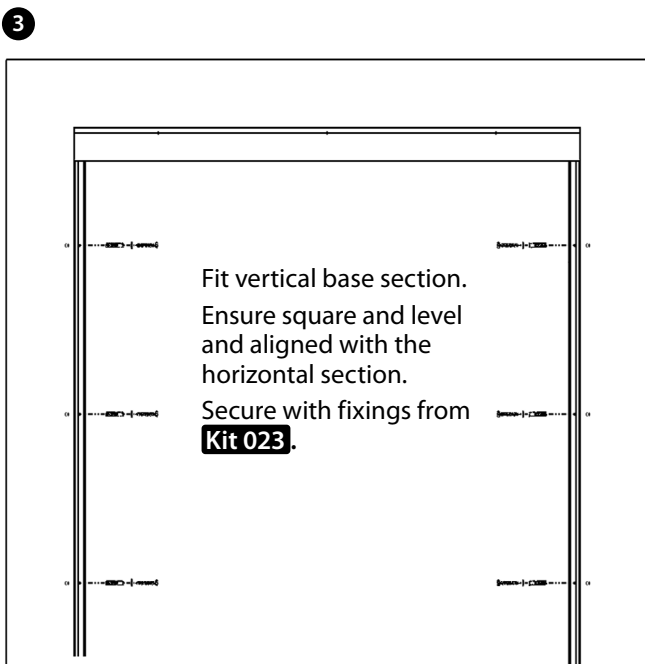

Fit vertical base section. Ensure square and level and aligned with the horizontal section. Secure with fixings from **Kit 023**.

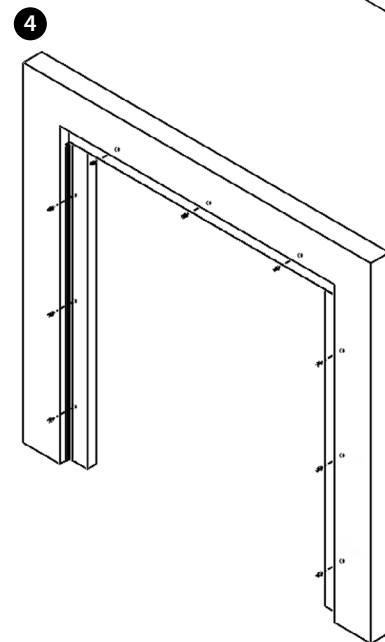

Fit vertical frame section. On inside, secure all covers to base with fixings **Kit 025**. Once secured, on outside face, seal edges of frame to structure with sealant.



Only remove wing screw after mounting door leaf (without top section).

ATTENTION!

These springs are pre-tensioned!

Der Flügelschraube erst nach Torblattmontage (ohne Obere Sektion) entfernen

ACHTUNG!

Die Federn haben Vorspannung!

Enlever la vis à oreilles une fois le tablier (sans la section haute) monté.

ATTENTION!

Les ressort sont pré-tendus!

Vleugelschroef pas verwijderen na montage deurblad (zonder topsectie).

LET OP!

De veren zijn voorgespannen!

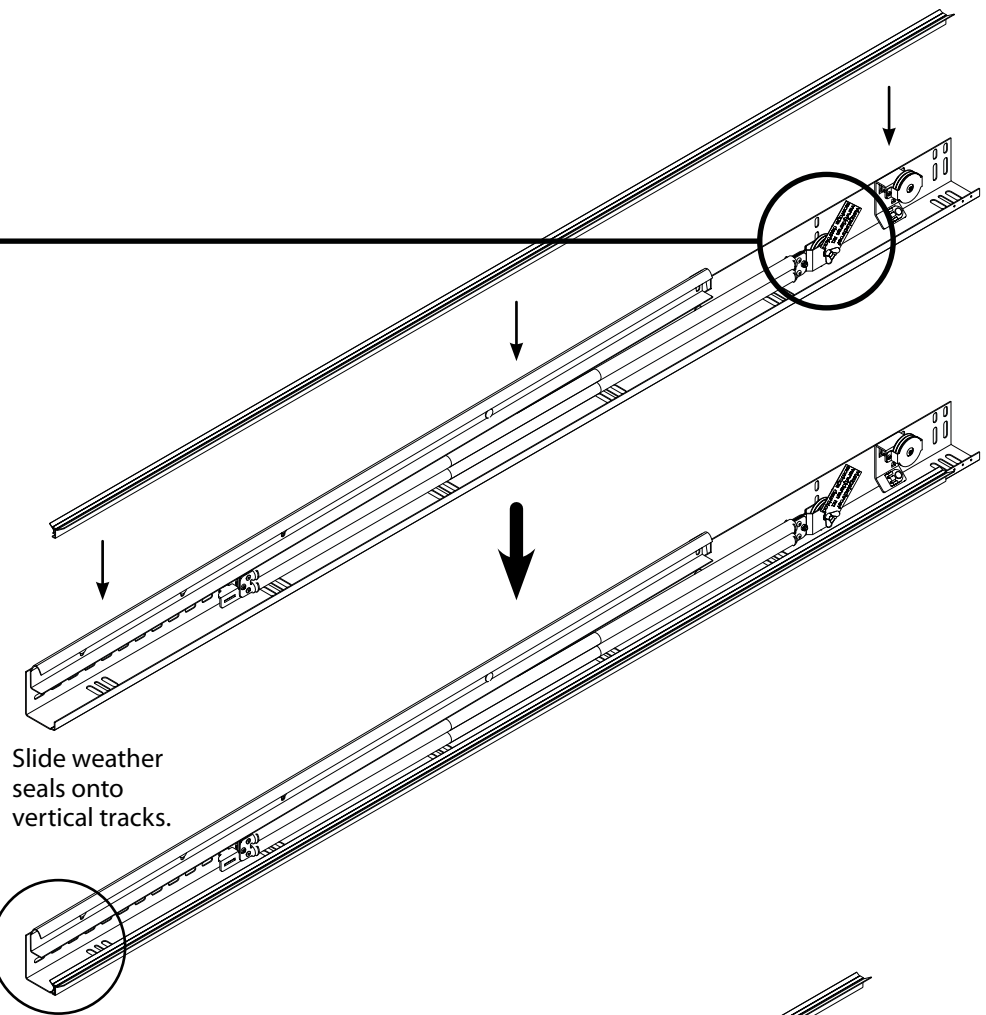

Slide weather seals onto vertical tracks.

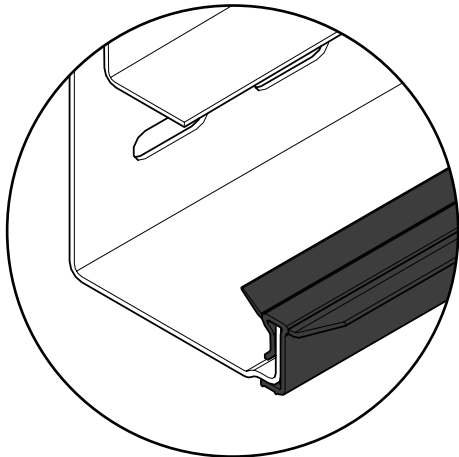

Seals are 100 mm larger then needed, cut down to suit the opening.

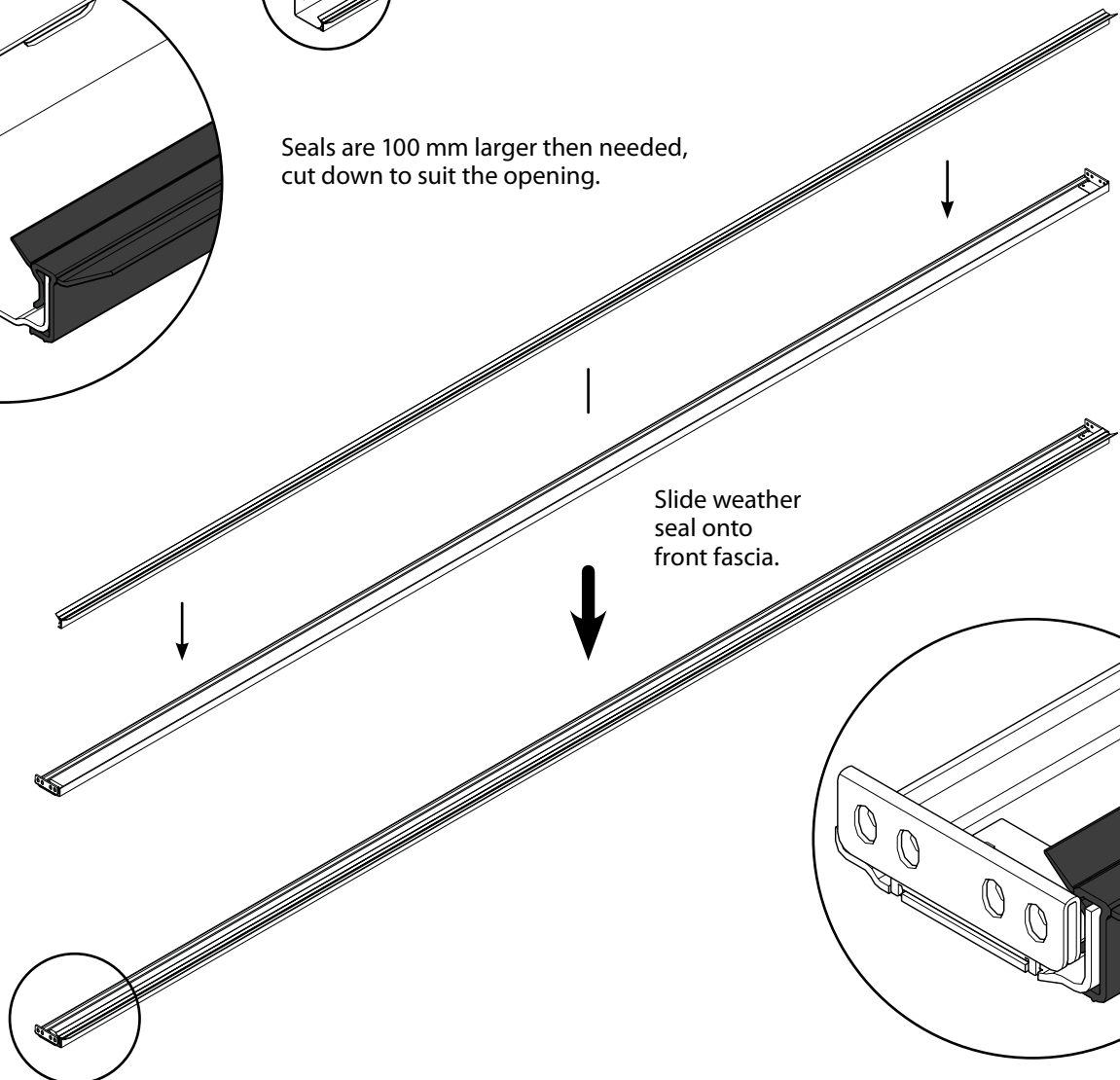

Slide weather seal onto front fascia.

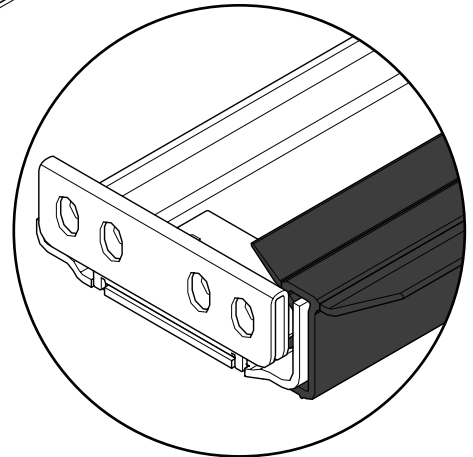

Reveal Brackets

Position 5 per side.
Secure each bracket with 2 M8 x 18
bolts and M8 serrated nuts.

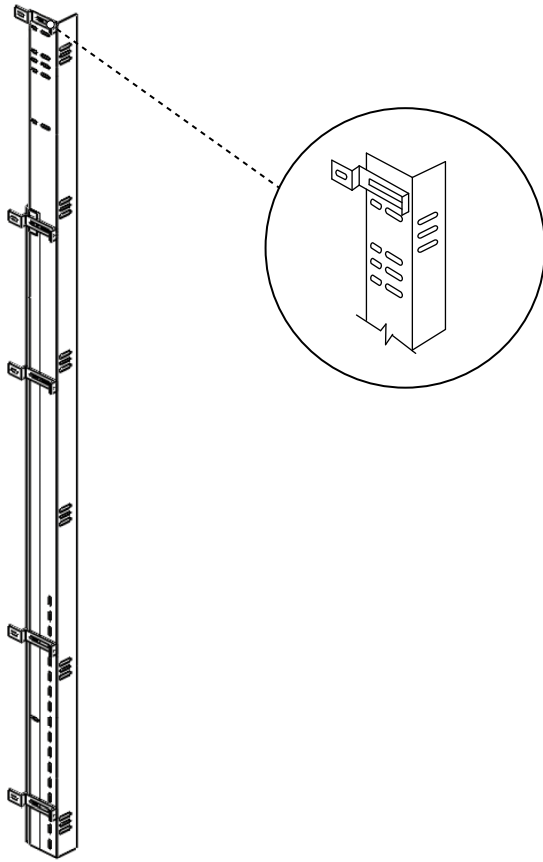

Kit 019 or 027

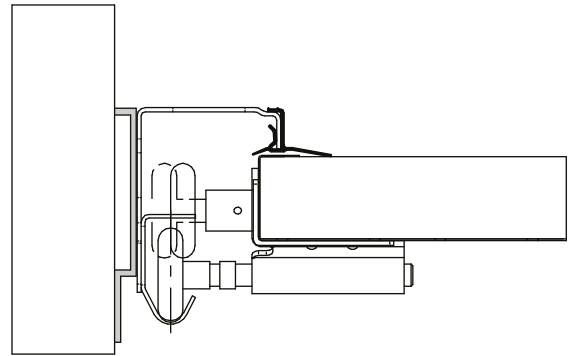

Face Fix

Kit 020 or 021

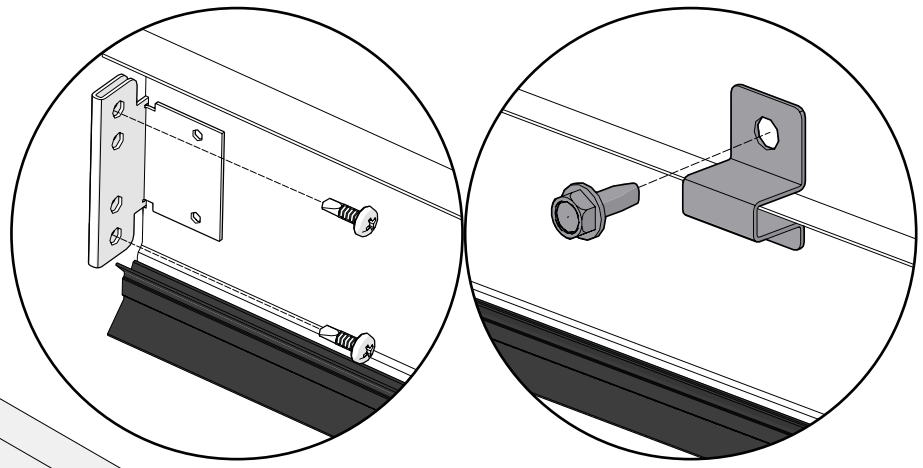
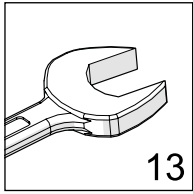

Lift fascia into place and secure.

Clamp to the wall
or to the executive
frame.

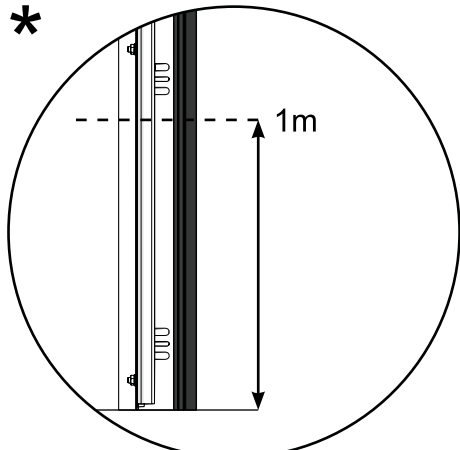
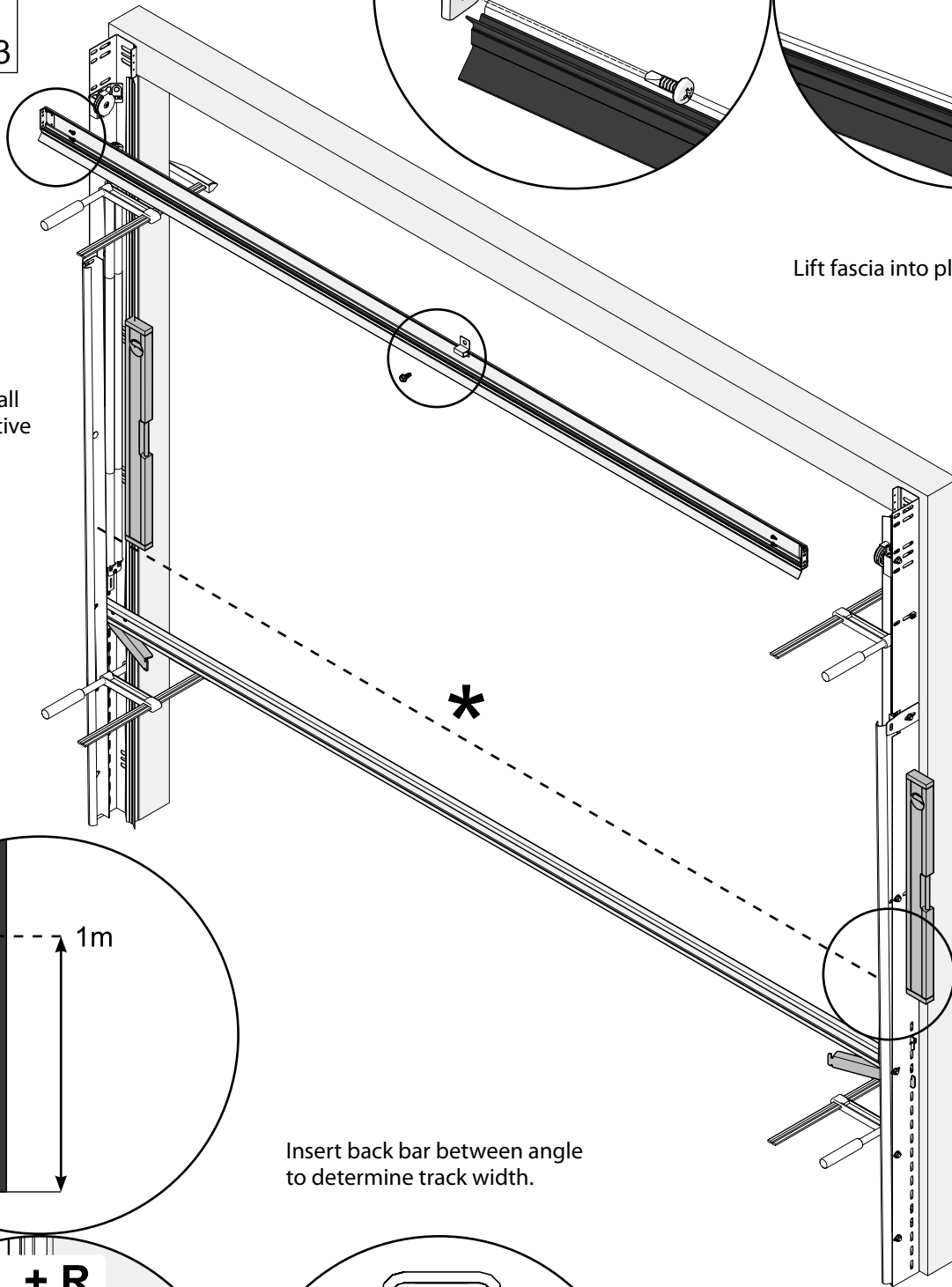

Insert back bar between angle
to determine track width.

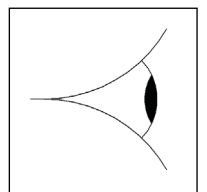
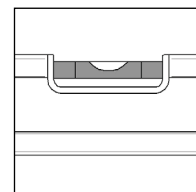
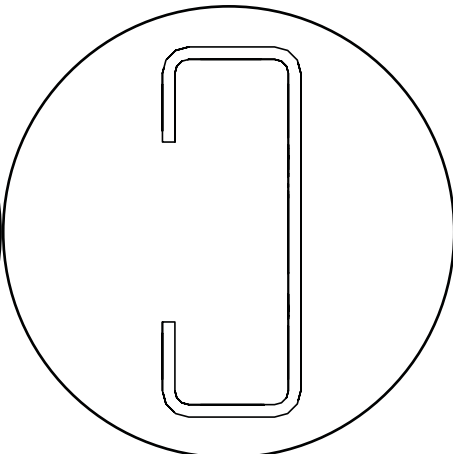
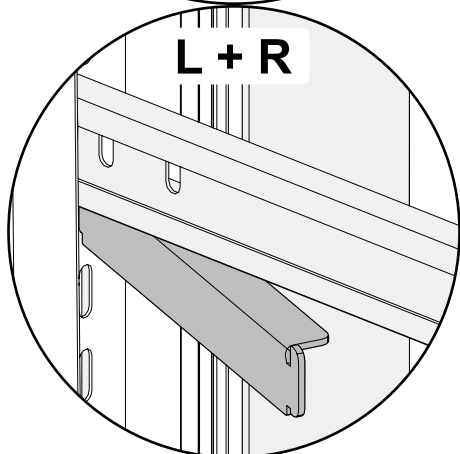

Once the frame is level, secure with the fixings below.

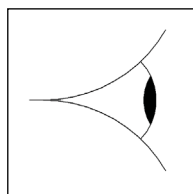
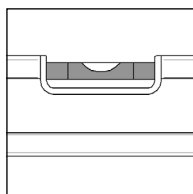
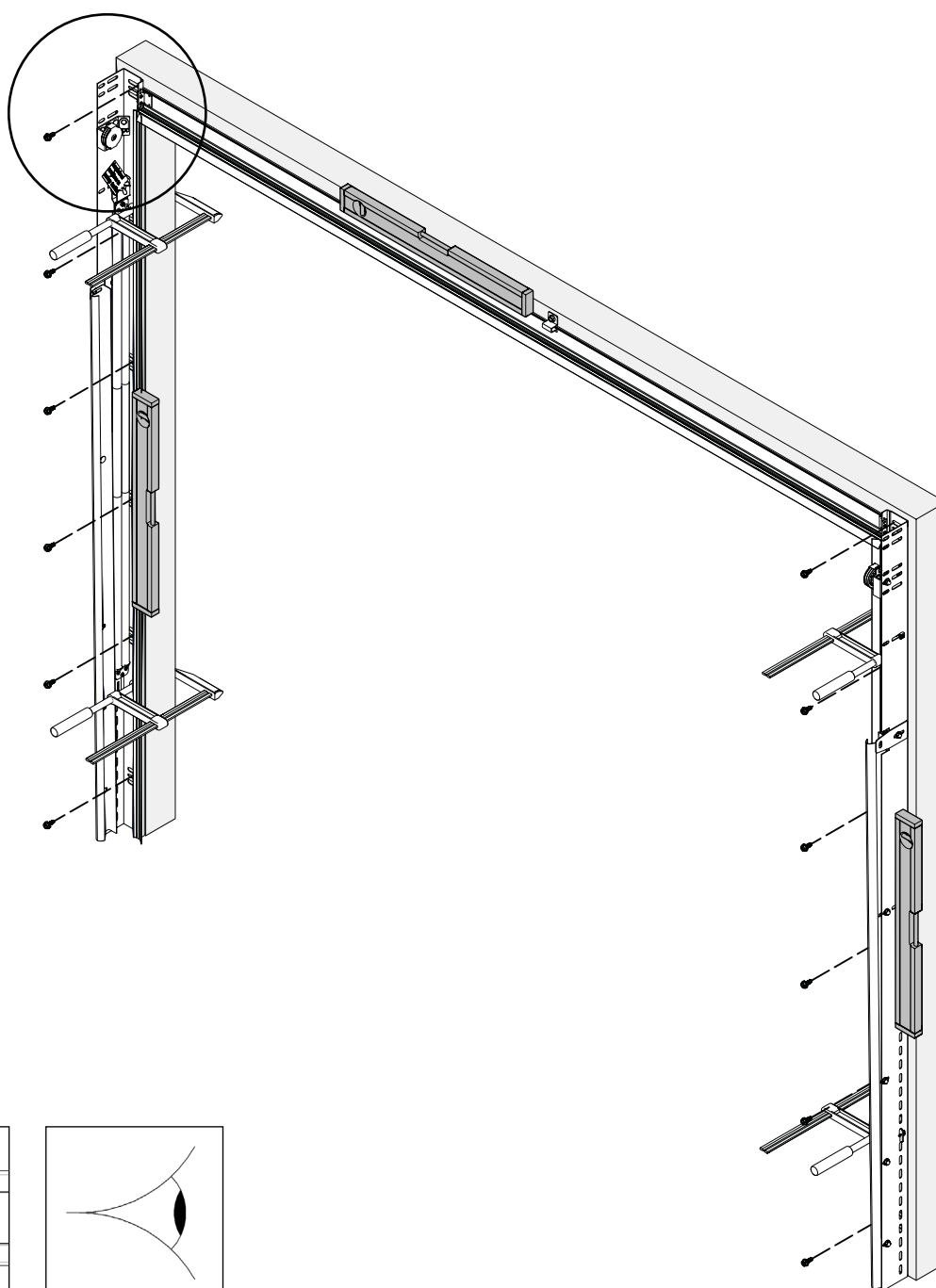
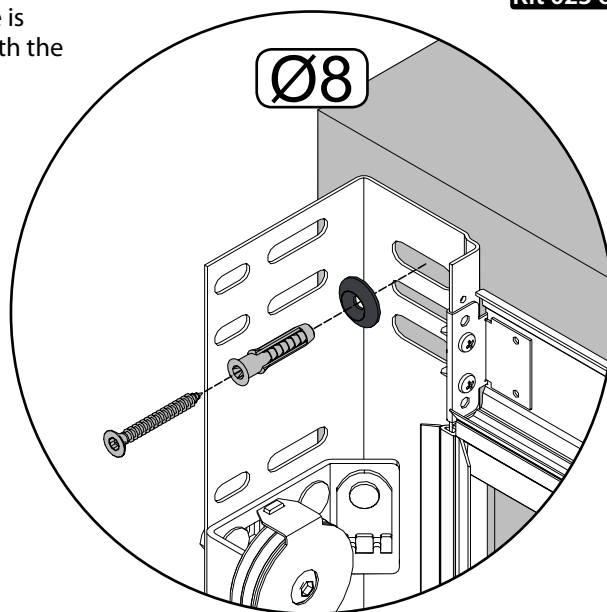
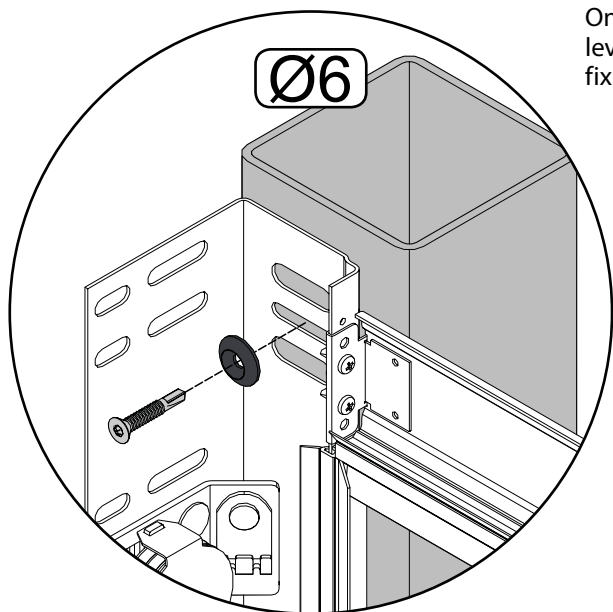

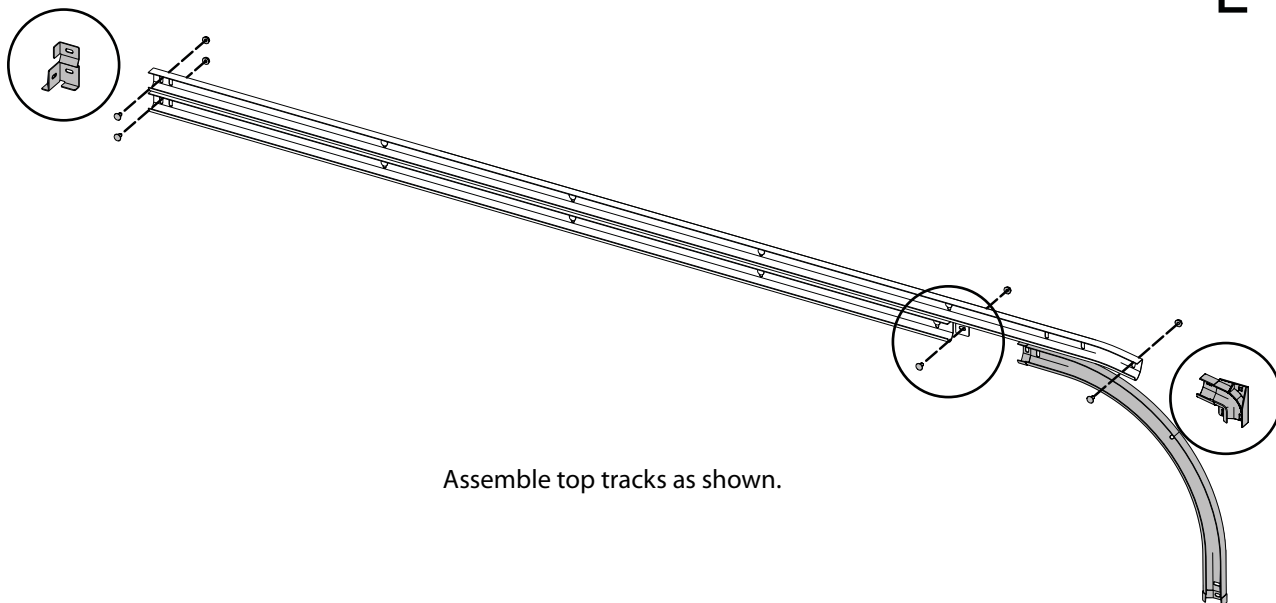

Assemble top tracks as shown.

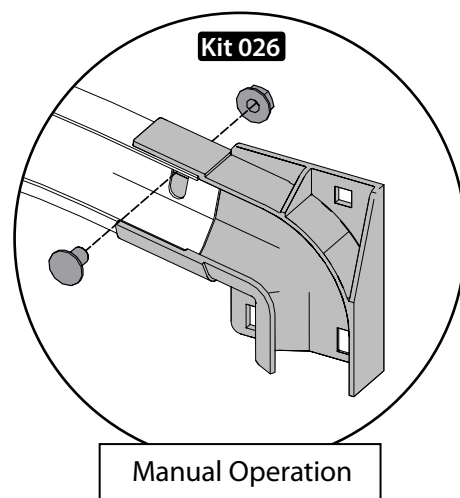
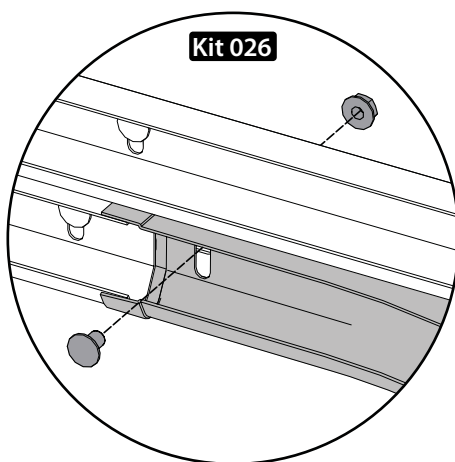
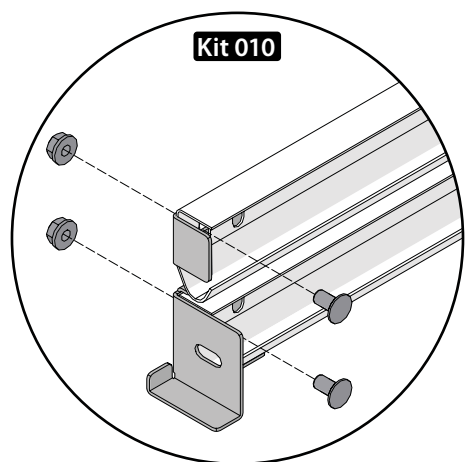

Assemble horizontal tracks as shown.

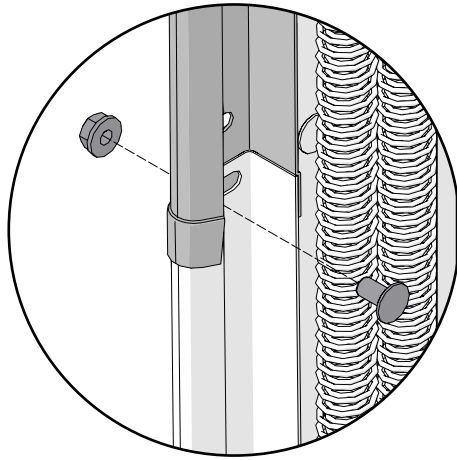
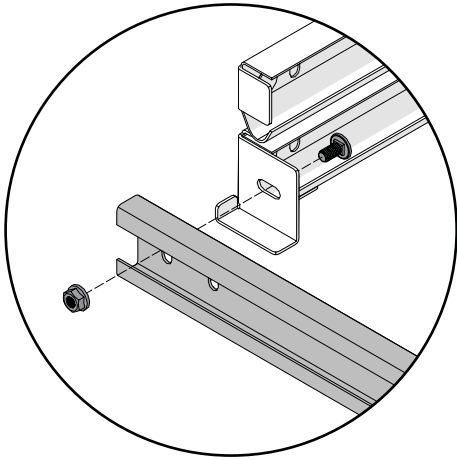
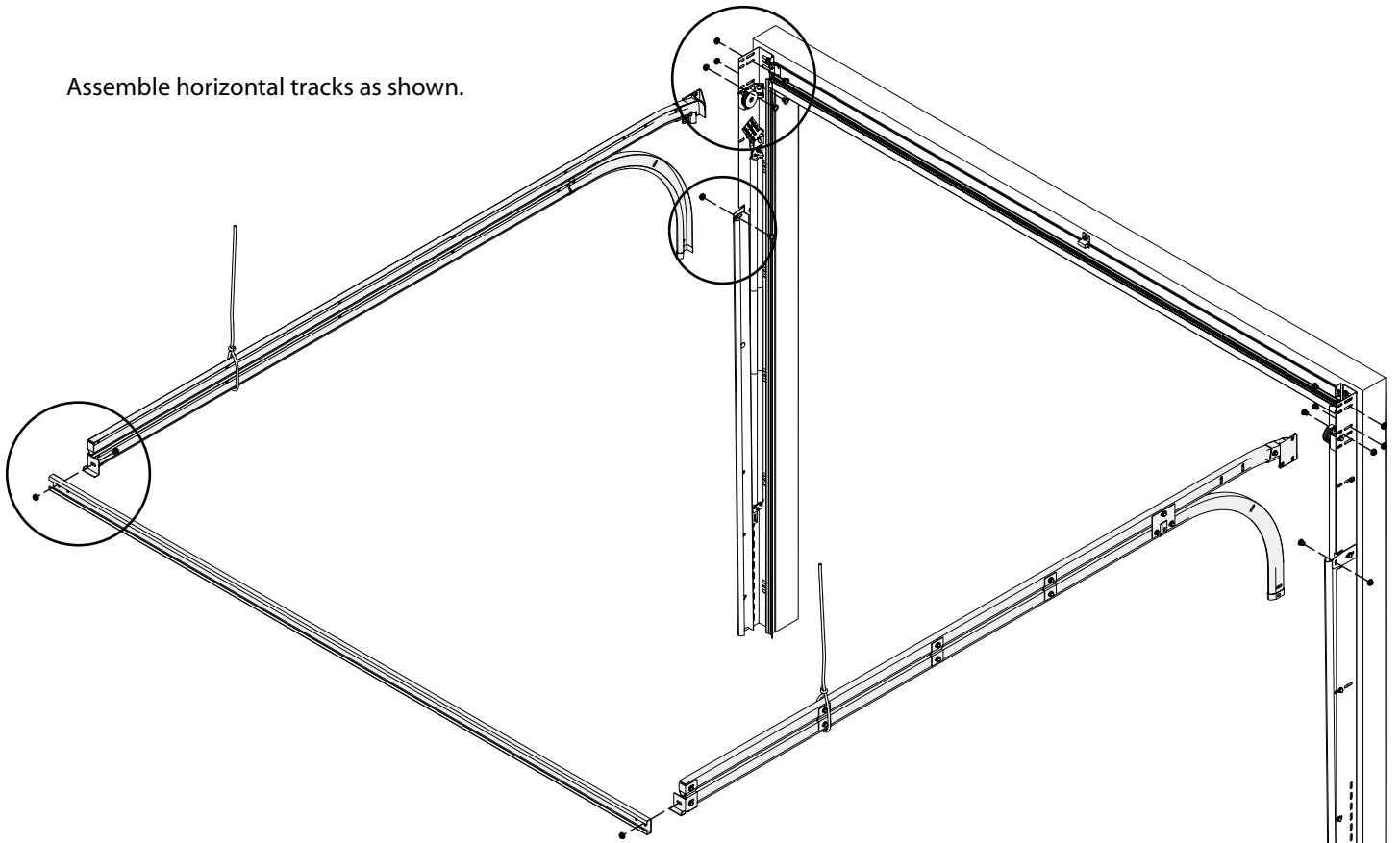

Kit 026

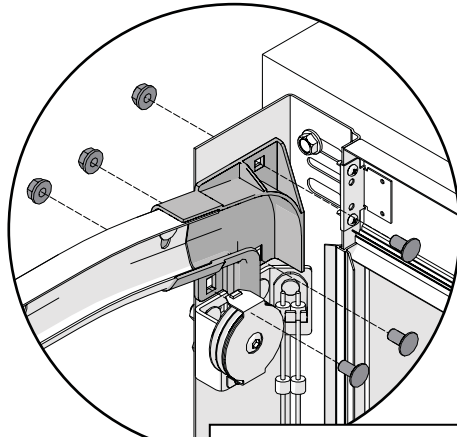

Manual Operation

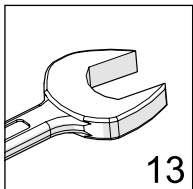
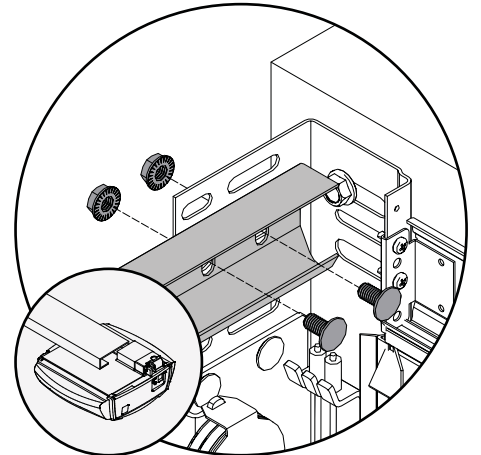

13

Fit reinforcing plates to horizontal track and radius

Kit 026

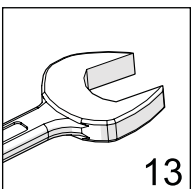
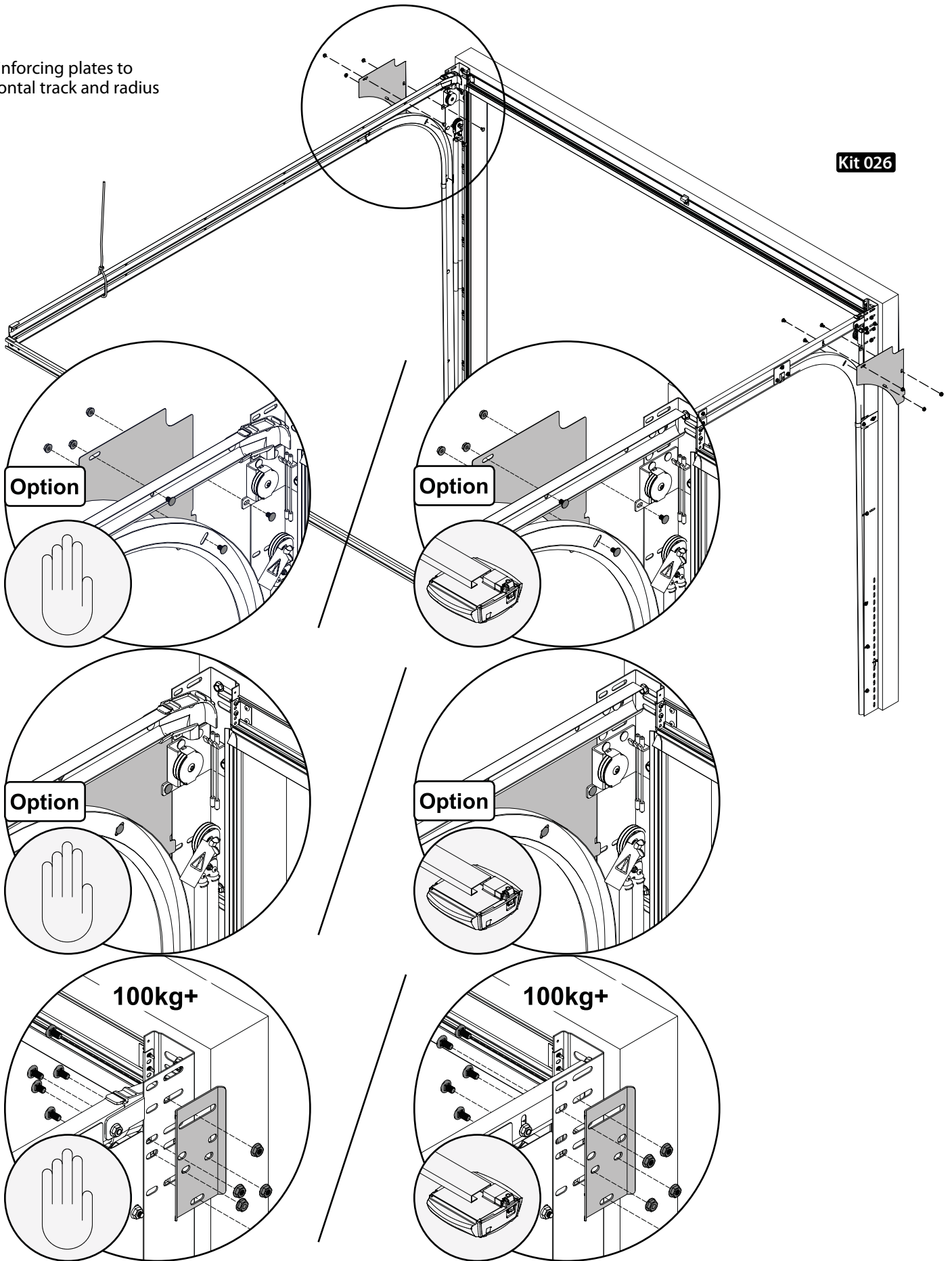

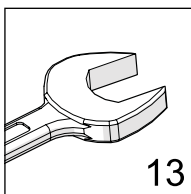
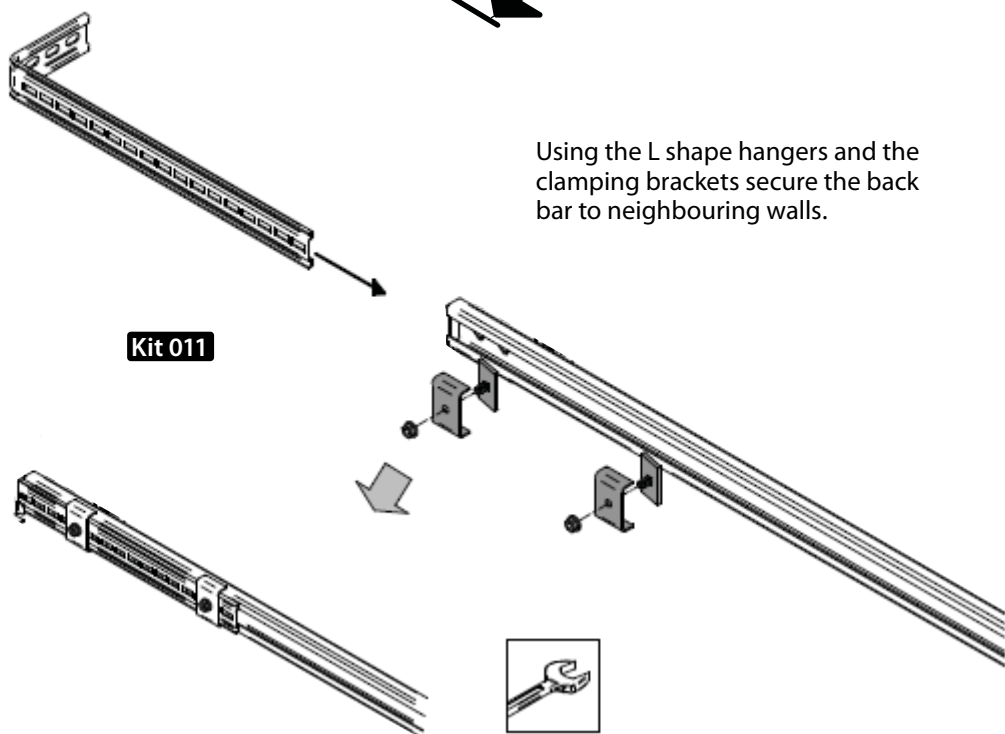
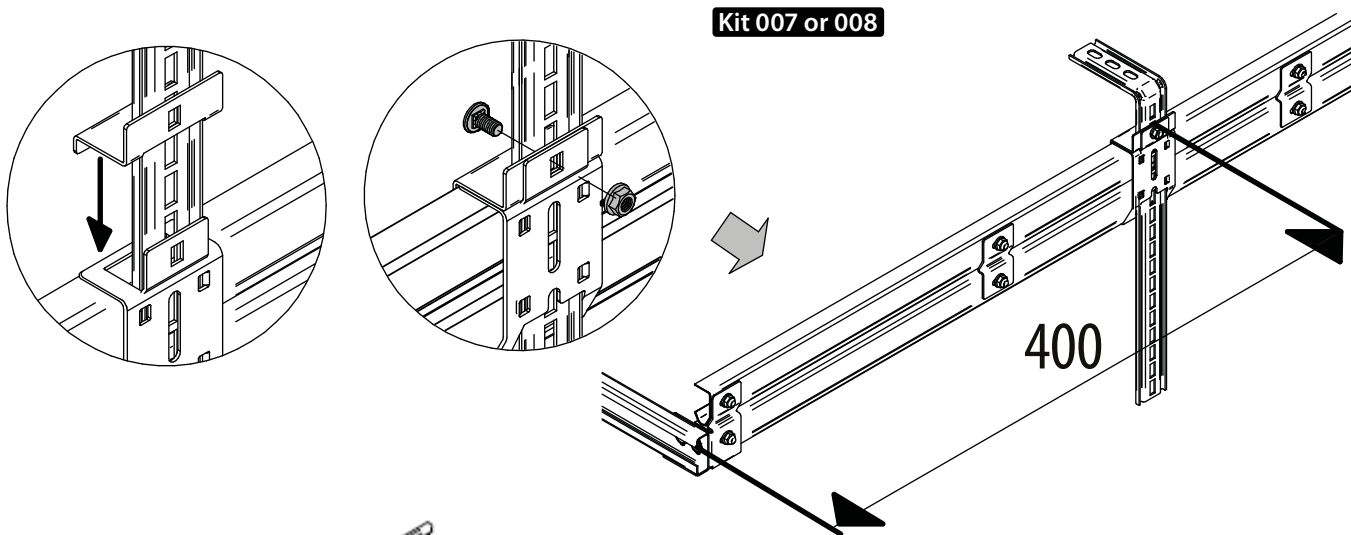
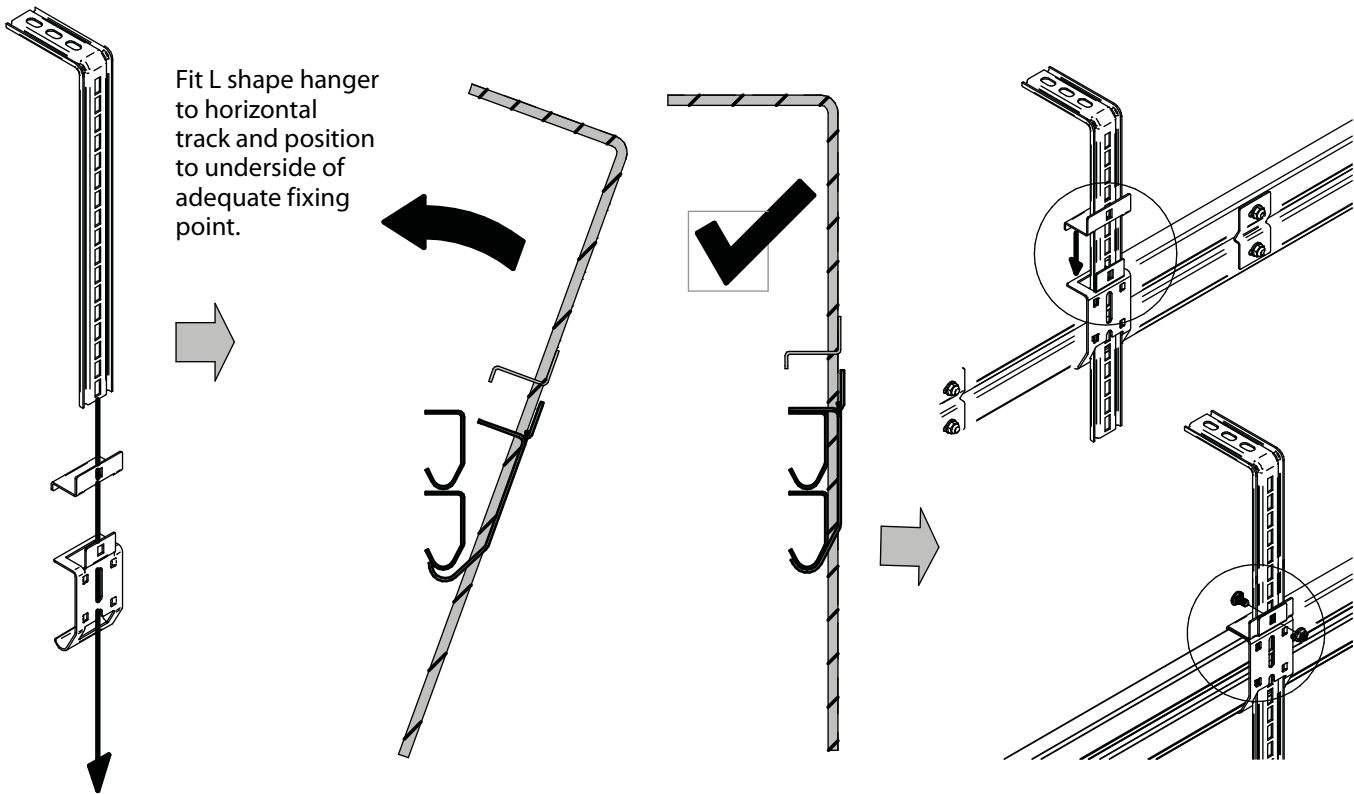

A = B
C = D

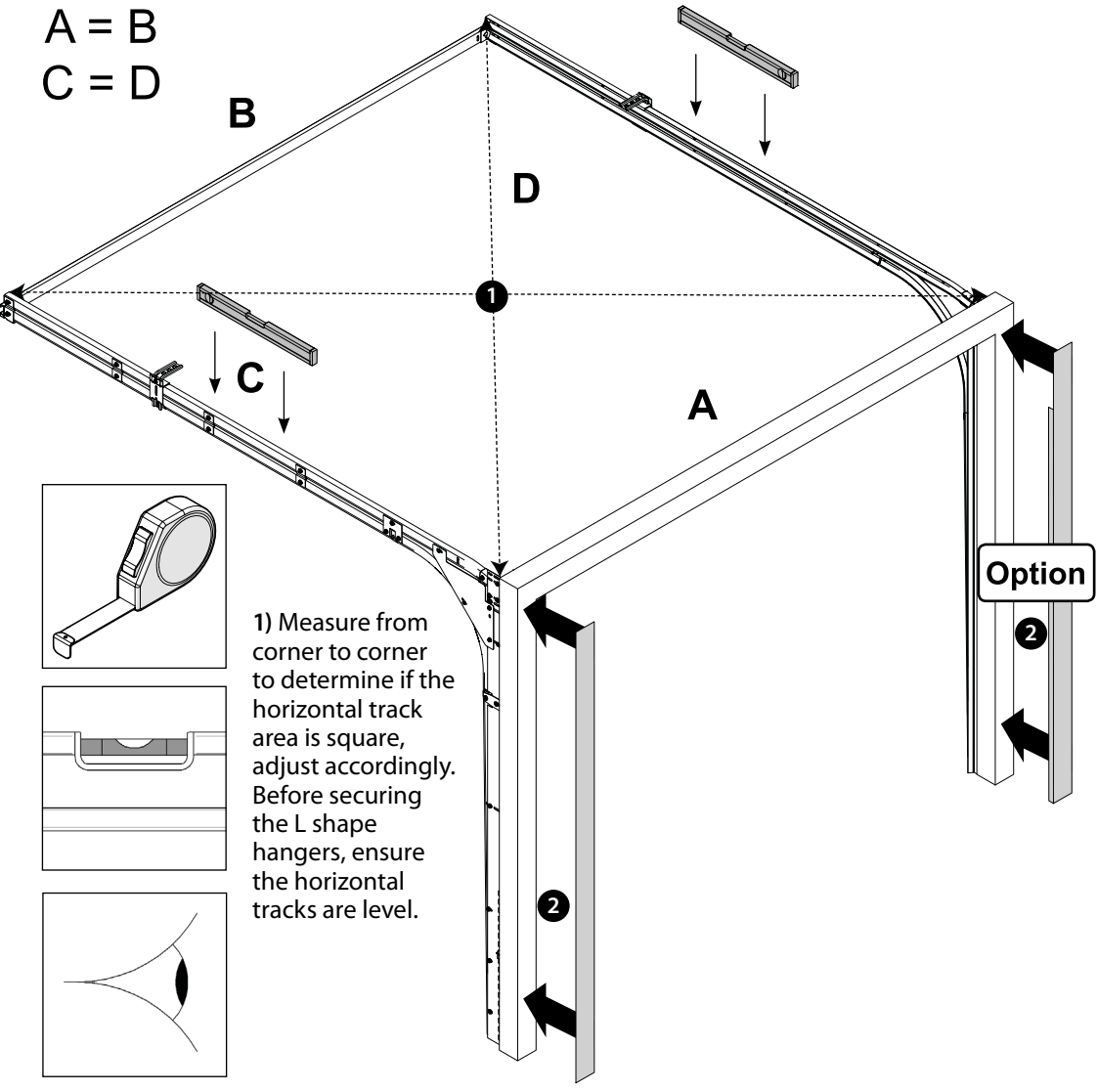

1) Measure from corner to corner to determine if the horizontal track area is square, adjust accordingly. Before securing the L shape hangers, ensure the horizontal tracks are level.

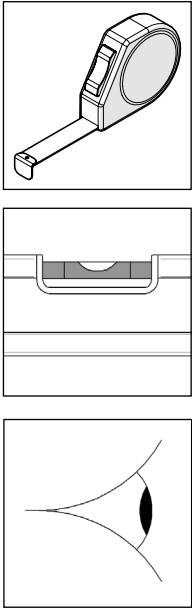

Cover Profiles Option

2) Once you have fitted the frame and tracks, fit the side profiles to the front of the vertical tracks.

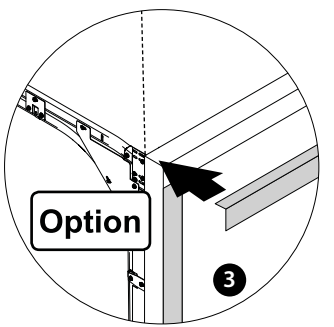

3) Secure the front header profile with 5 mm rivets or with liquid nails.

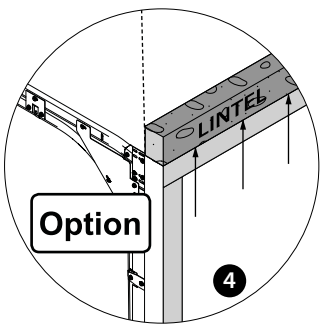

4) If necessary, you can fix the header profile to the under side of lintel.

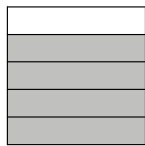

Fix roller brackets to panels.

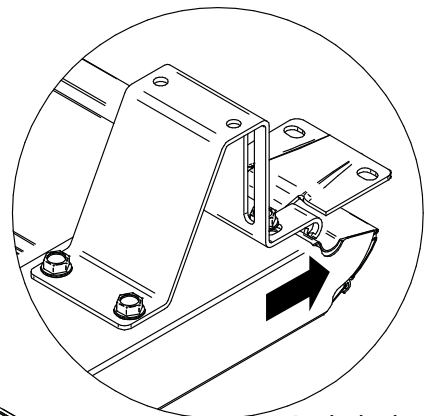
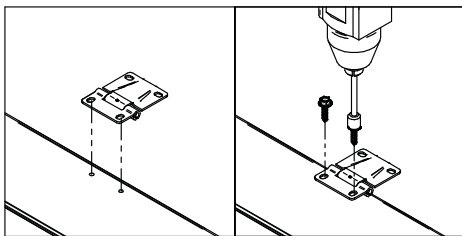

Push the hinge towards the top of the panel.

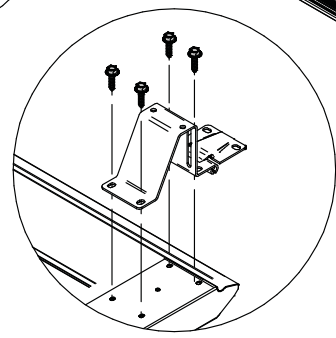
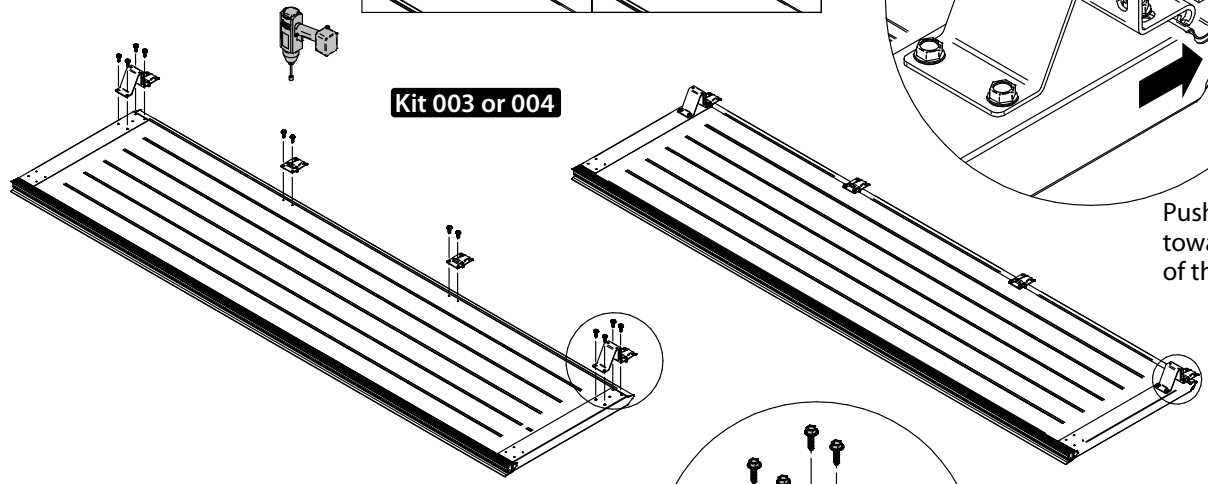

Kit 013 or 014

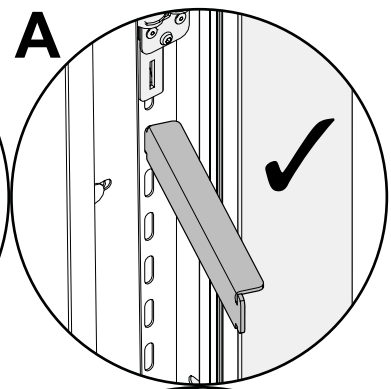
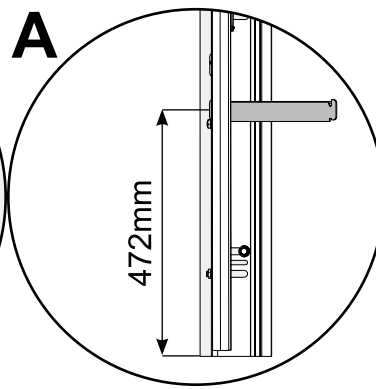
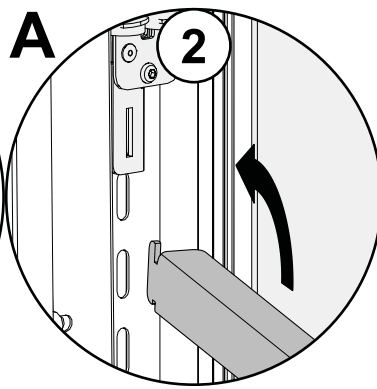
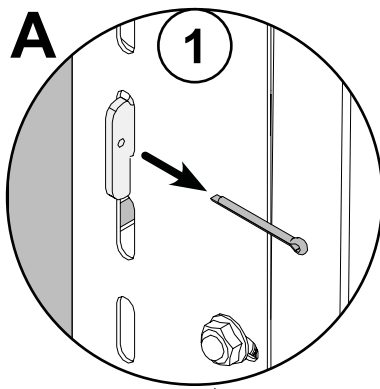

Insert the support bracket into position.

Kit 015, 016, 017 or 018

Lift the panel gently to the support bracket.

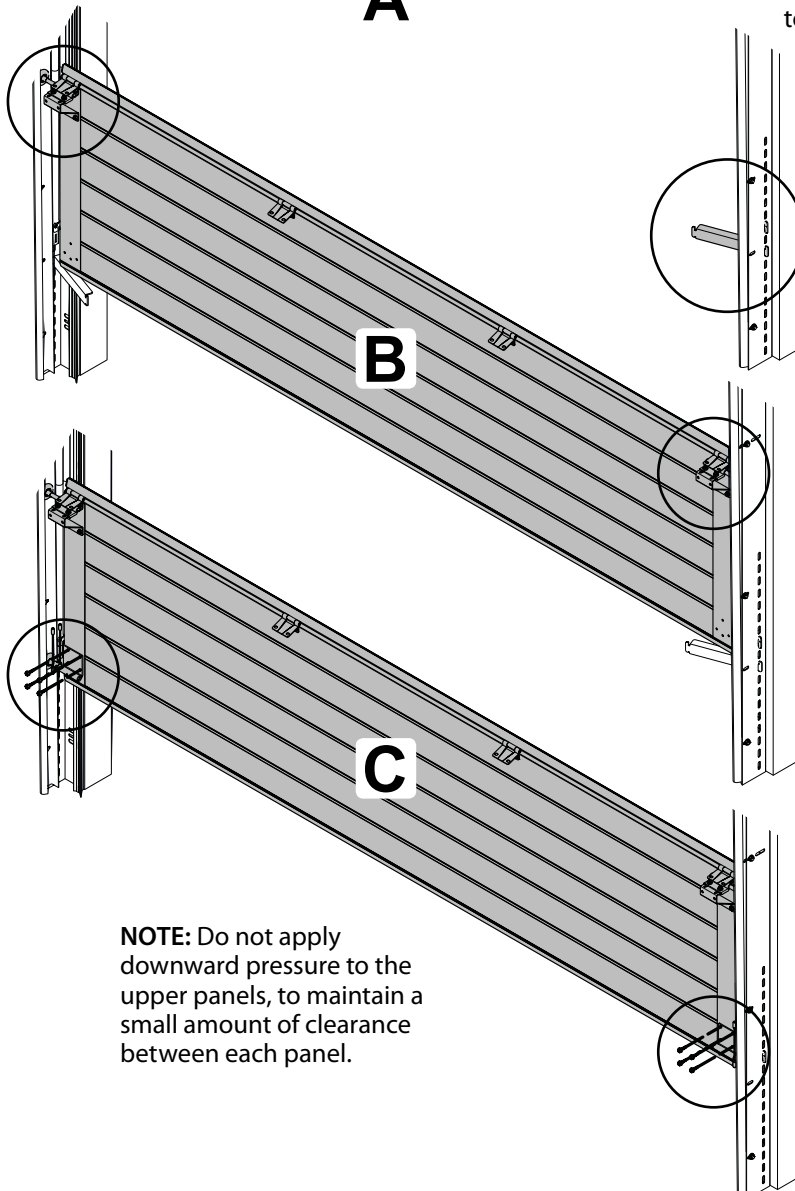
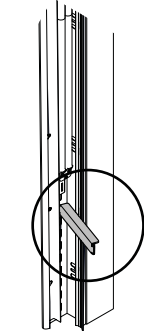
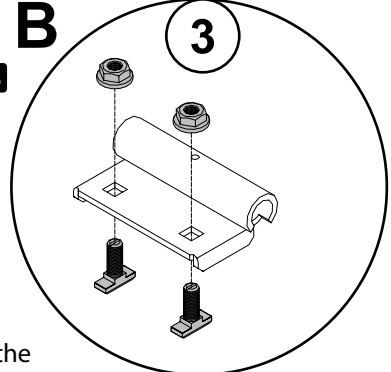

Insert roller into the top of the panel.

Kit 013 or 014

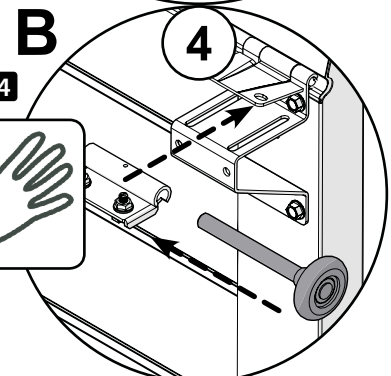

Feed the roller through the bottom of the cable.

Kit 005

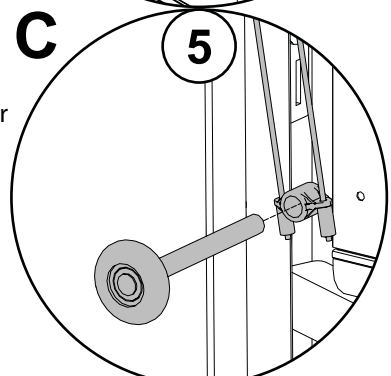

NOTE: Do not apply downward pressure to the upper panels, to maintain a small amount of clearance between each panel.

Secure the bottom of the roller to the base of the bottom panel. Repeat on both sides.

Kit 005

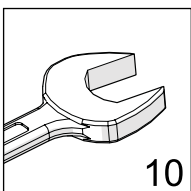
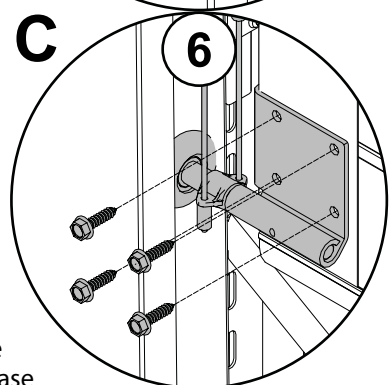

Once bottom rollers and brackets are secure, lift the panel gently and remove the support brackets.

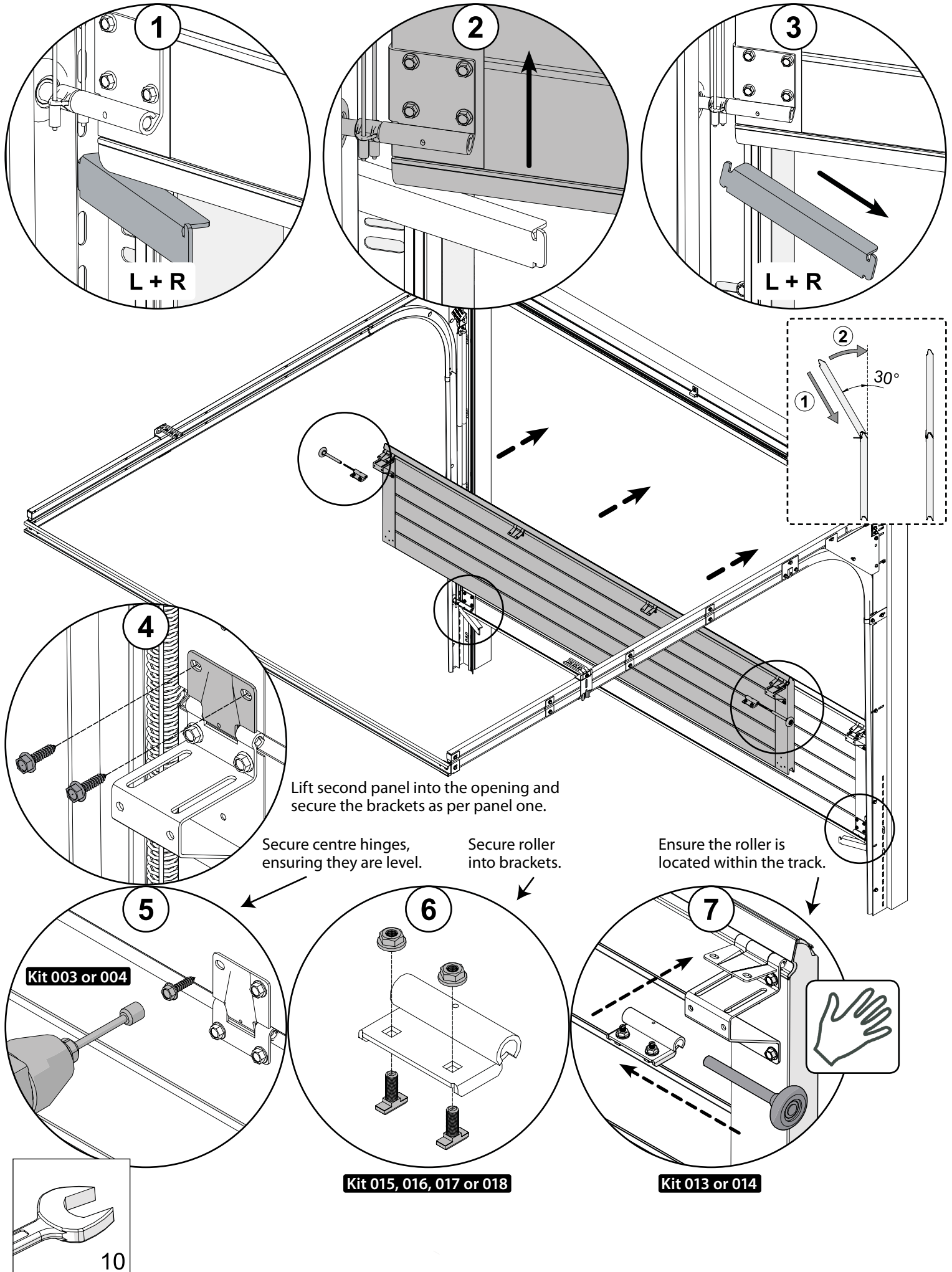

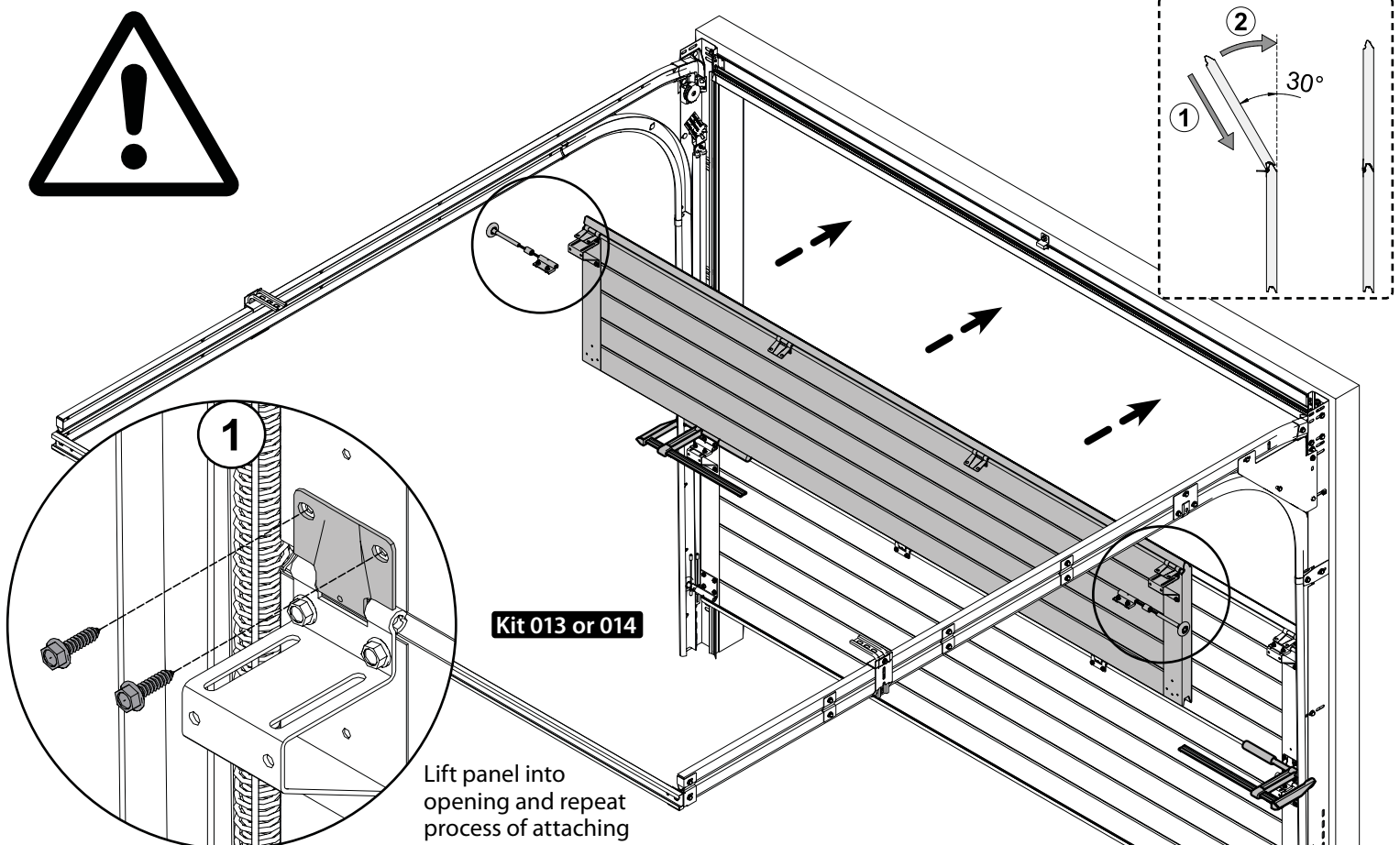
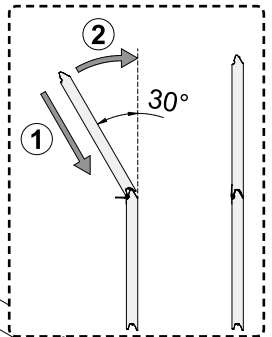

Kit 013 or 014

Lift panel into opening and repeat process of attaching brackets and rollers to the third panel.

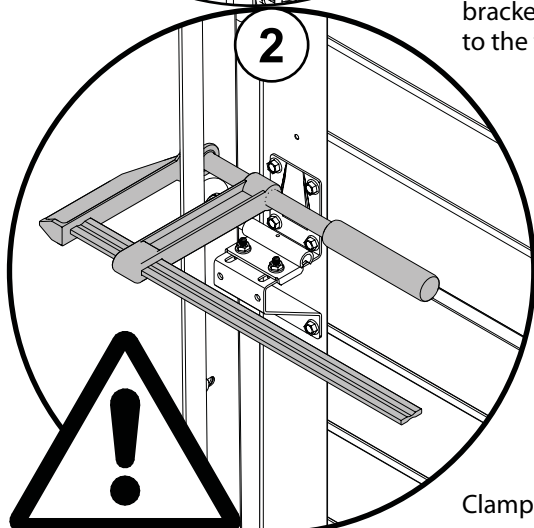

Clamp the door securely to prevent movement.

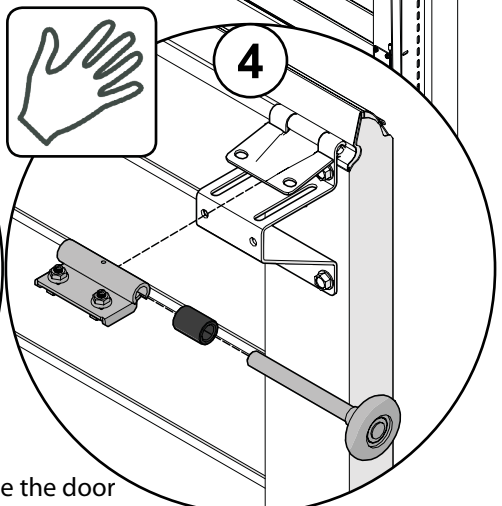
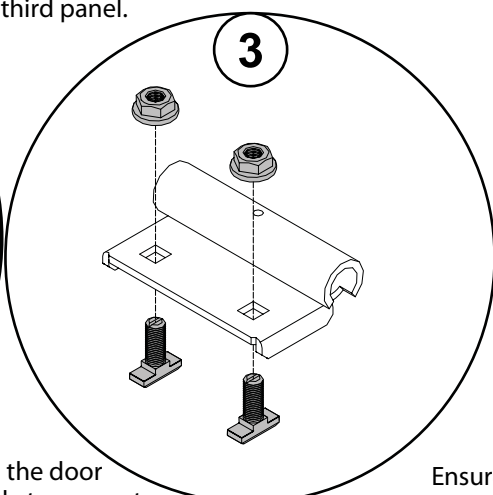

Ensure the door still remains clamped at this point.

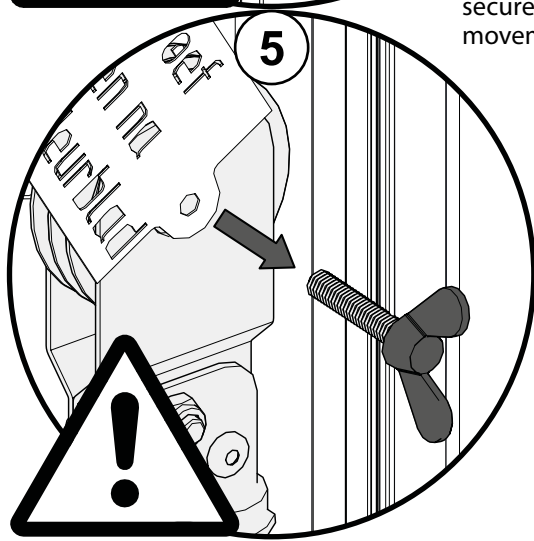

Before removing the red screws, ensure the door is clamped securely. Remove pin.

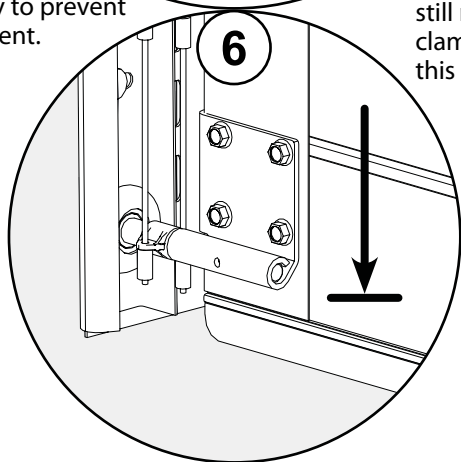

Push door securely onto the ground.

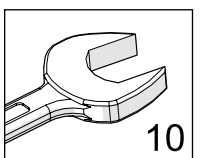
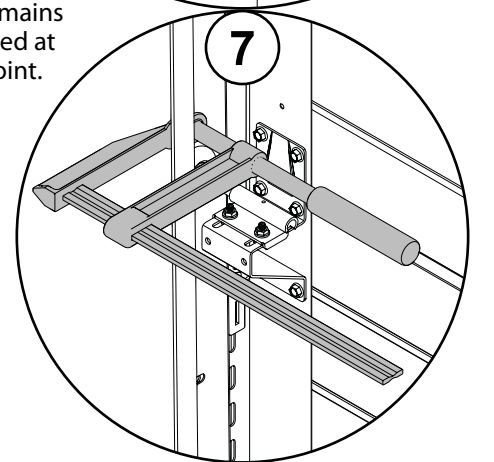

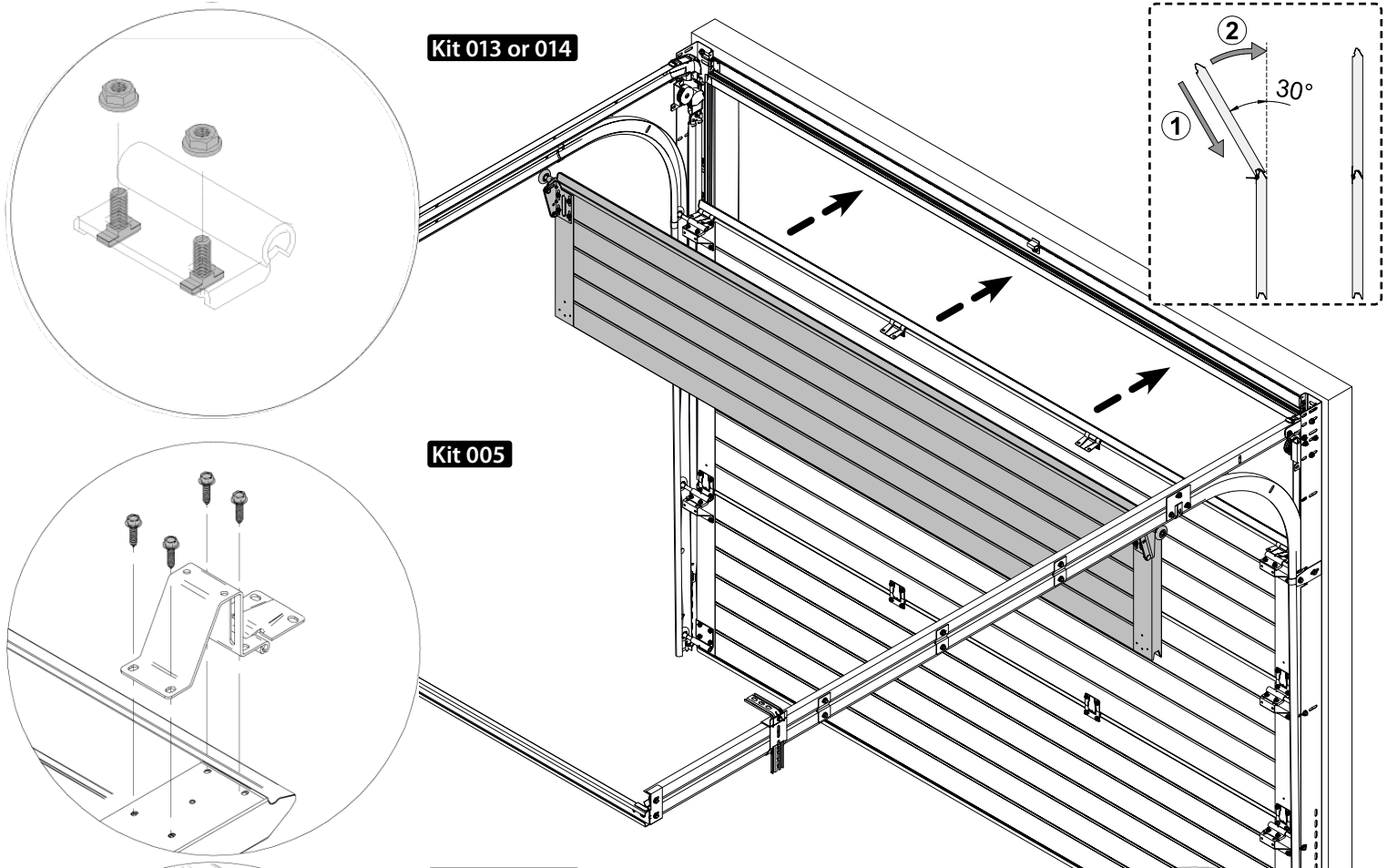

Kit 013 or 014

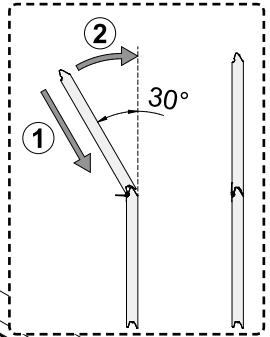

Kit 005

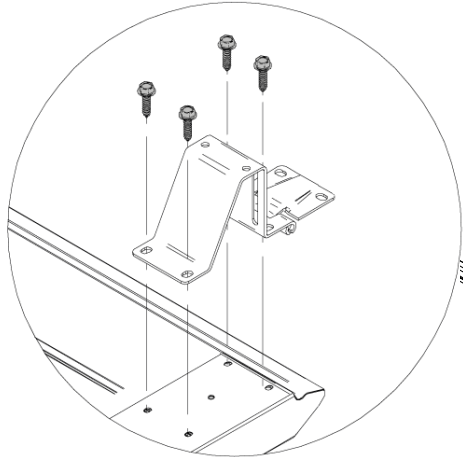

Kit 003 or 004

Ensure hinges are level and the pin is sat loosely in the panel ridge.

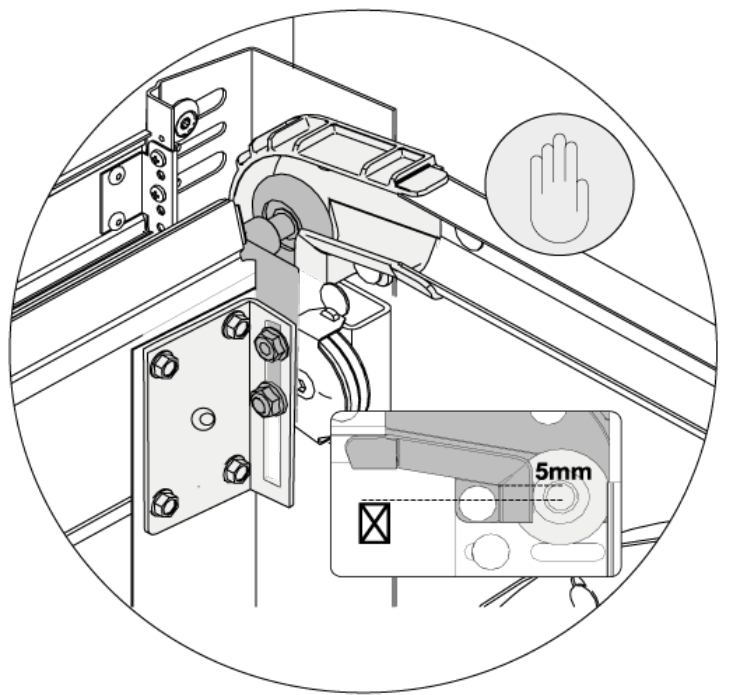
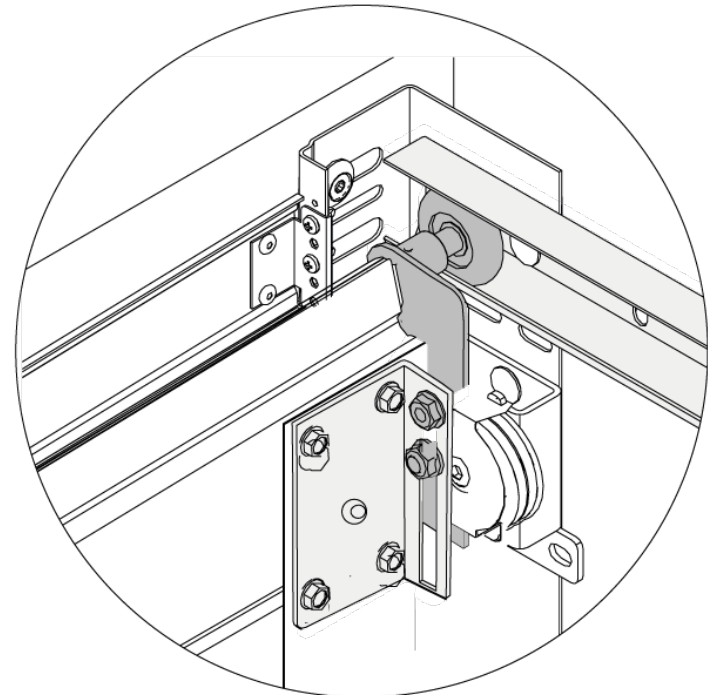
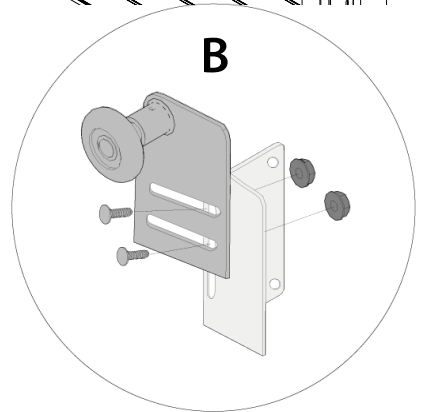
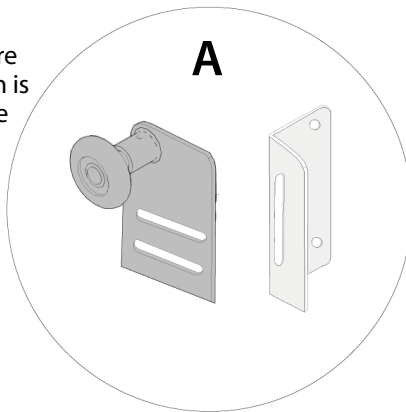
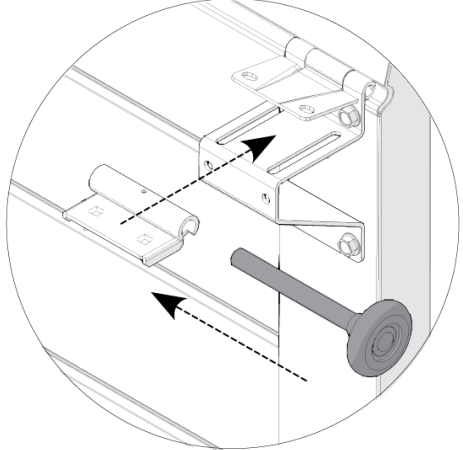

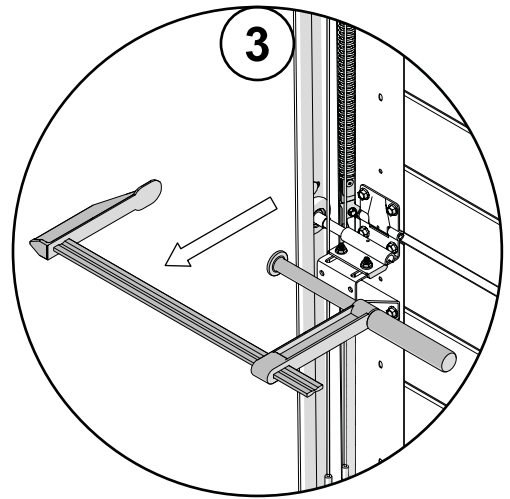
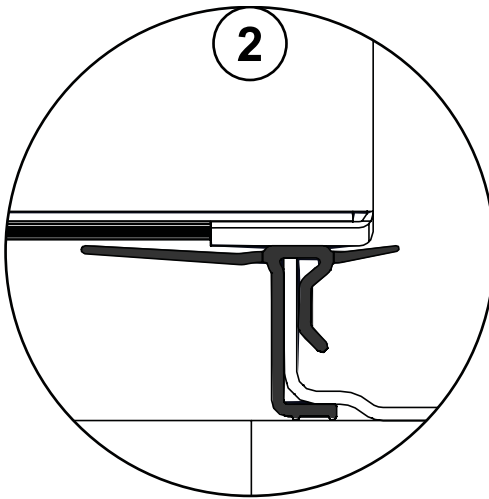
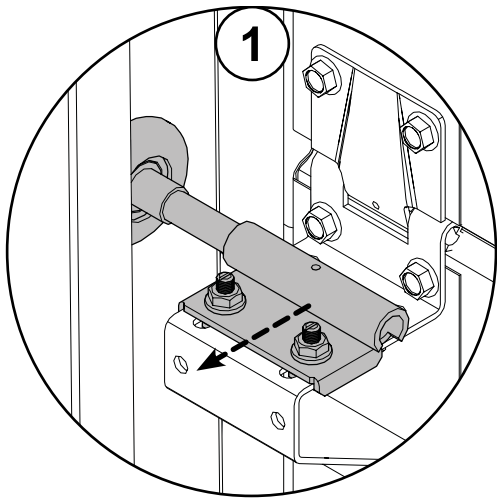
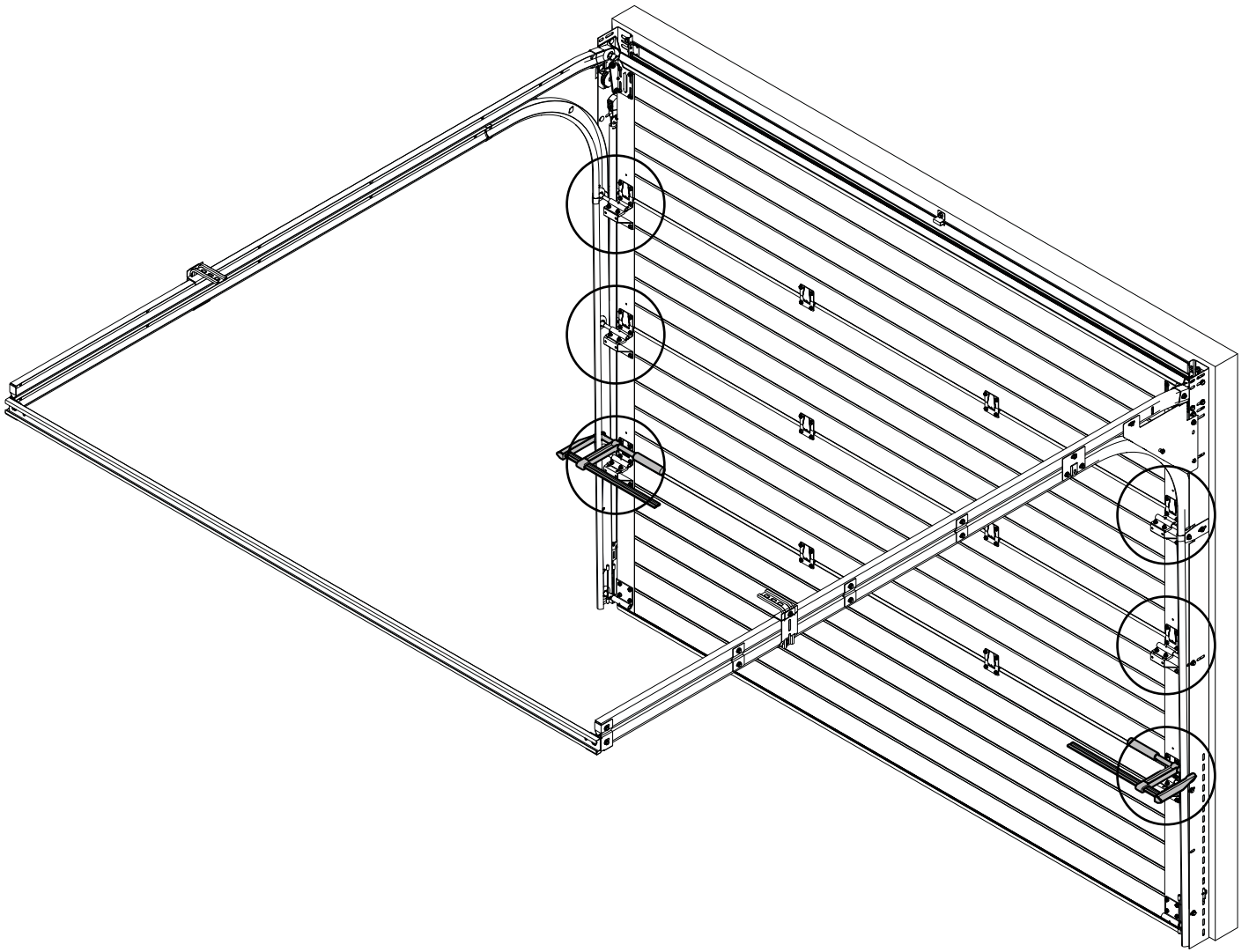

Position rollers & brackets so the roller can freely move within the track. Secure bracket when completed.

Adjust panel to suit the weather seal.

Remove clamp.

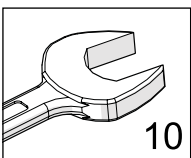

10

Lift door to fully open position.

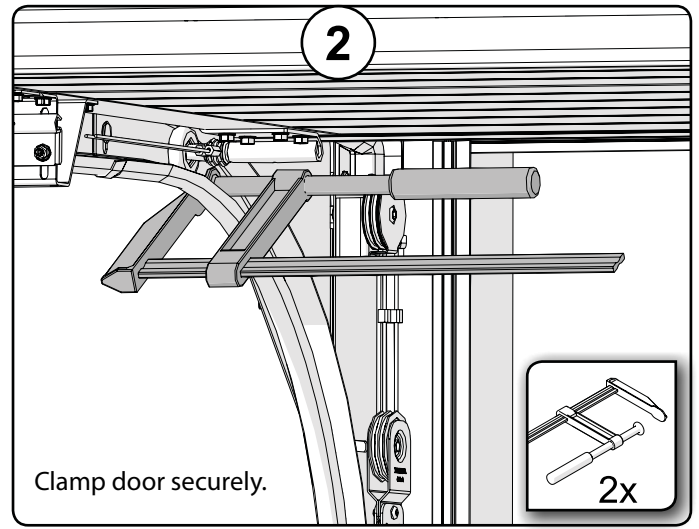
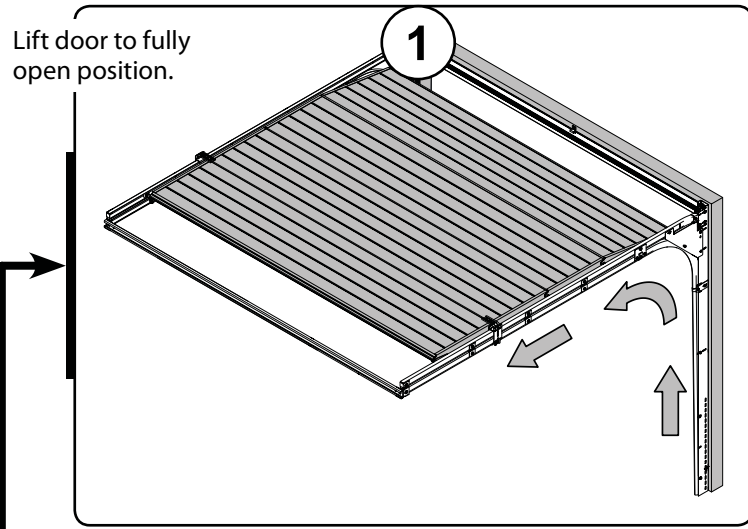

Clamp door securely.

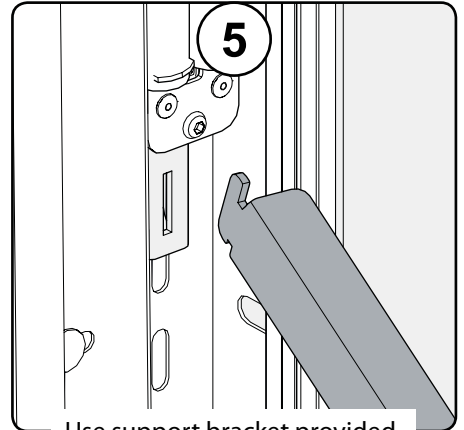
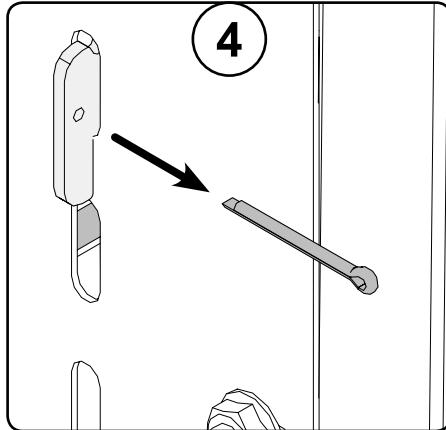
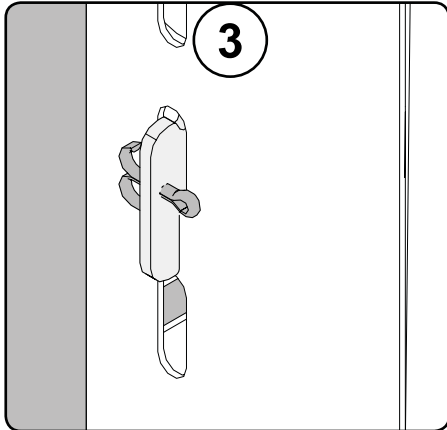
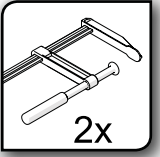

Use support bracket provided to release tension spring.

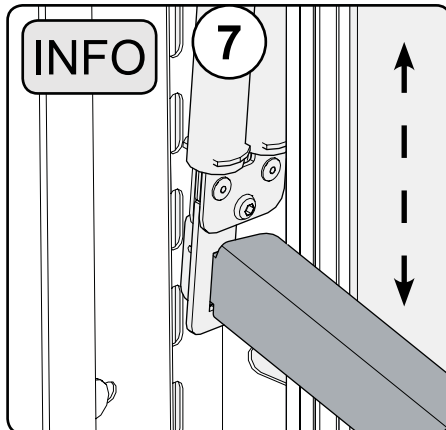
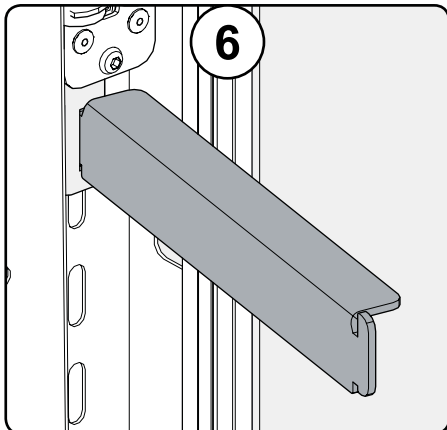

Move spring down or up to get the desired tension to balance the door.

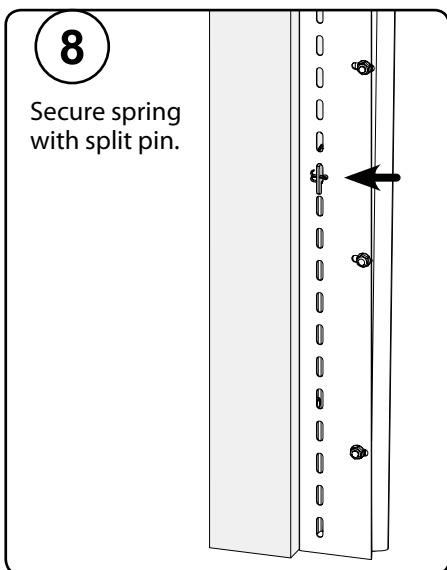

8

Secure spring with split pin.

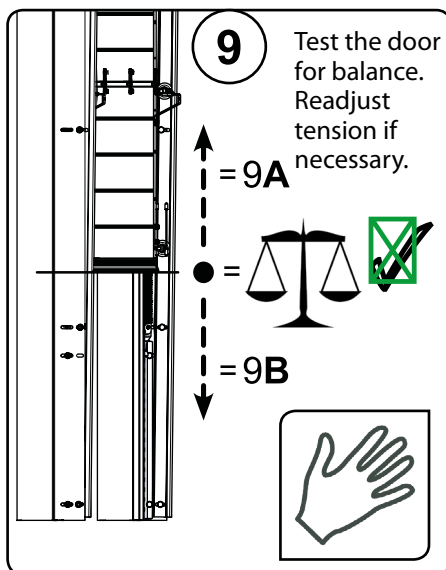

9

Test the door for balance. Readjust tension if necessary.

= 9A

= 9B

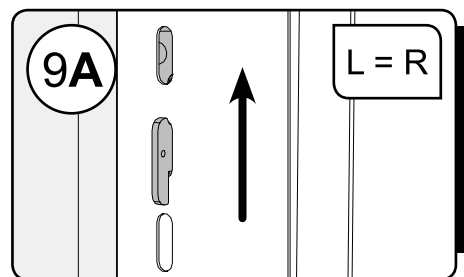

9A

L = R

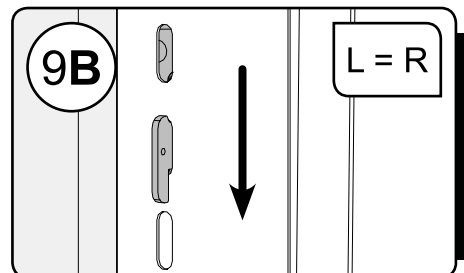

9B

L = R

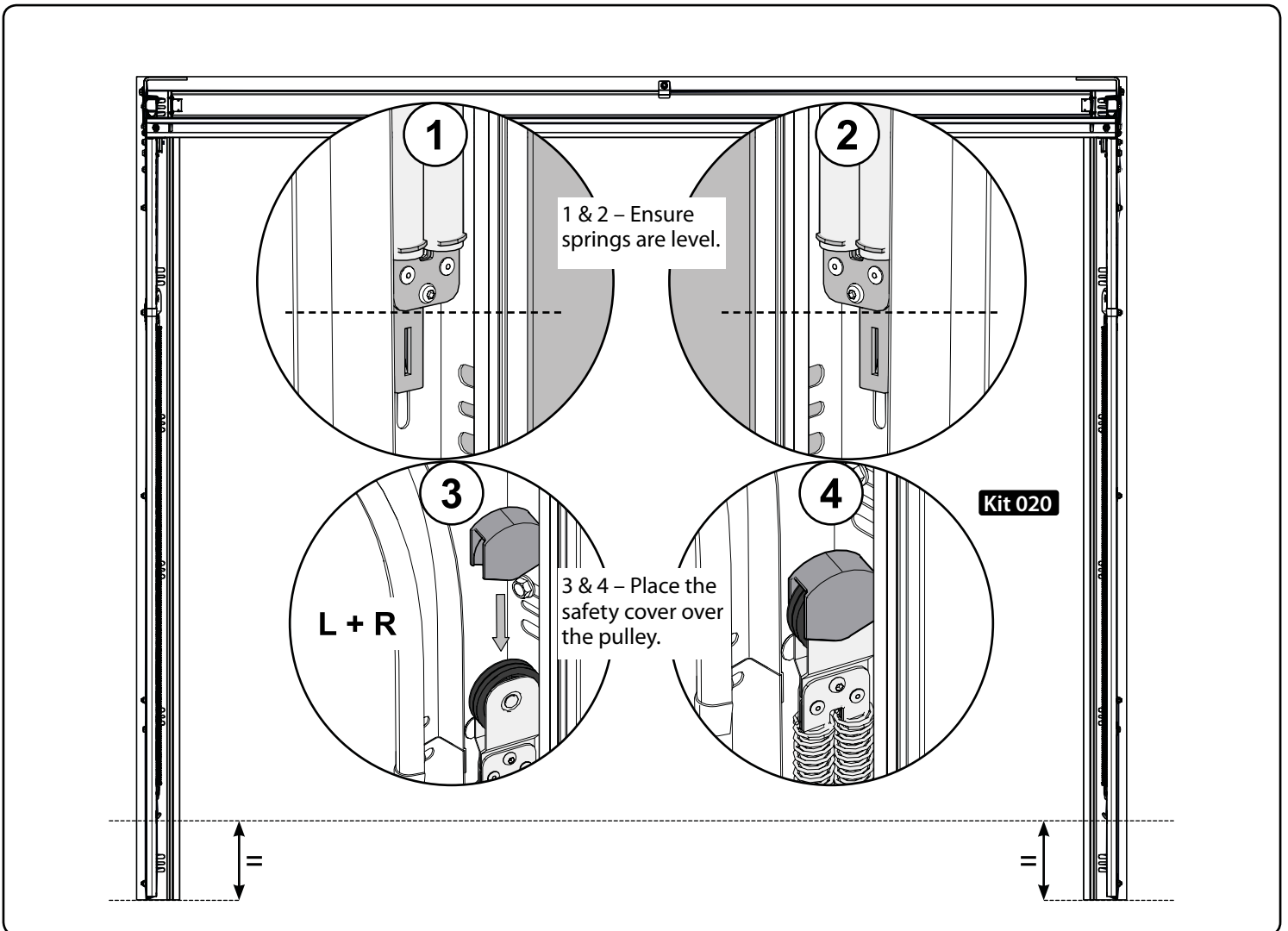
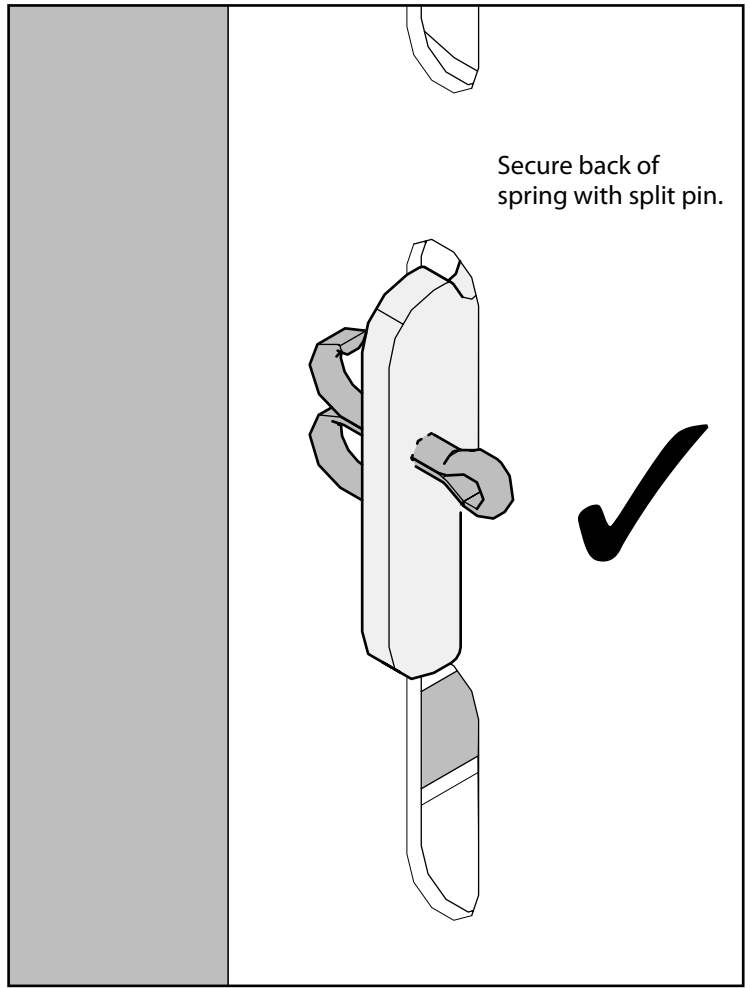
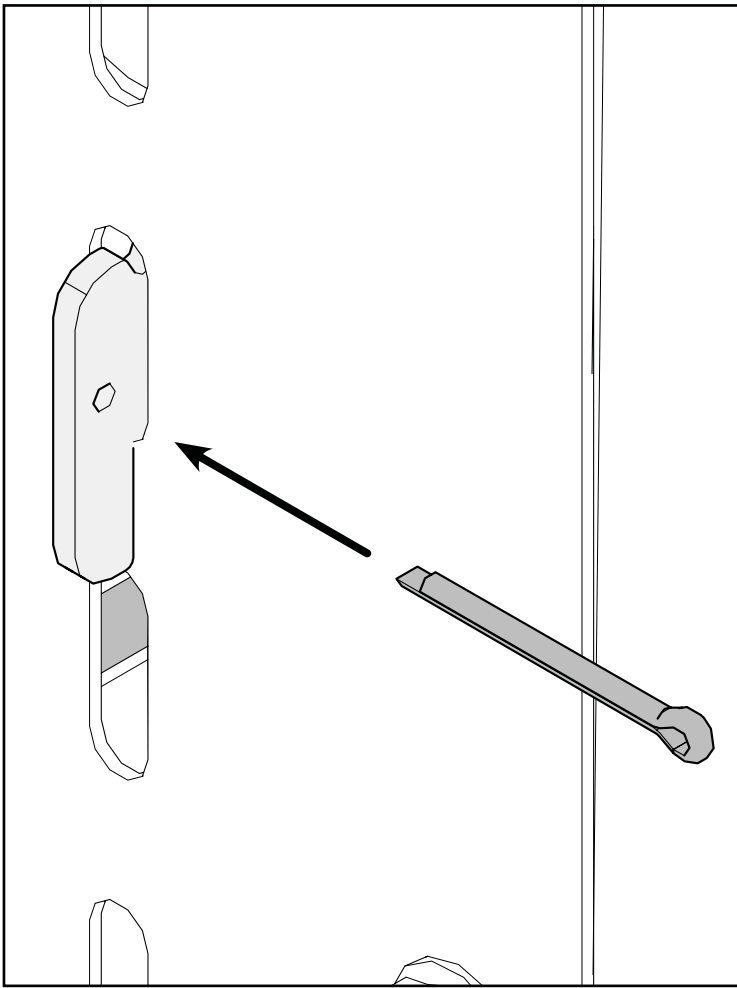

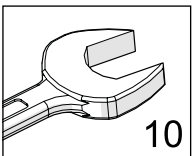
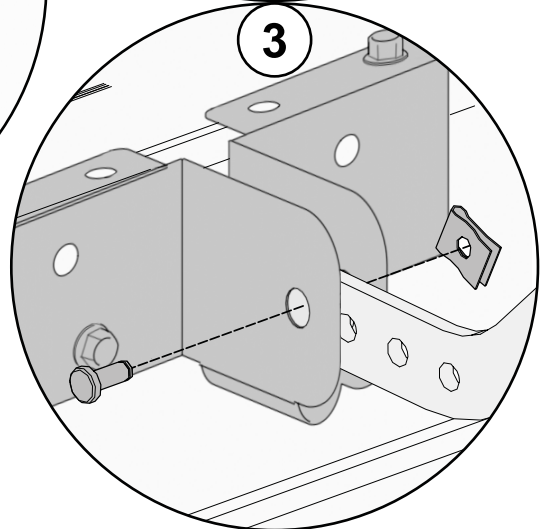
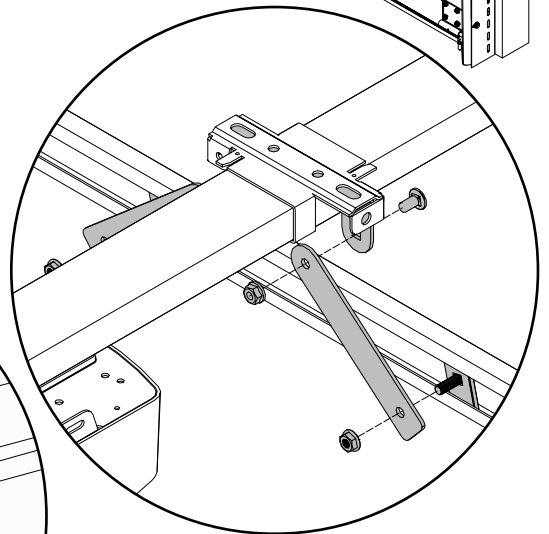
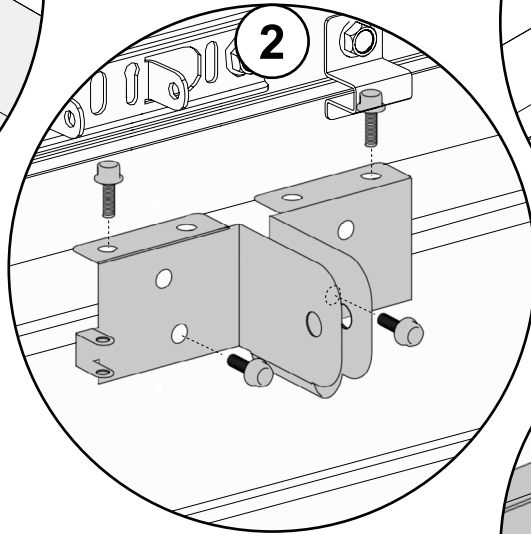
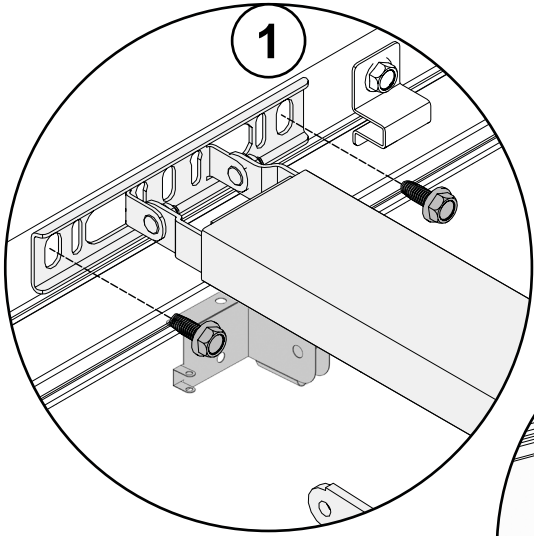
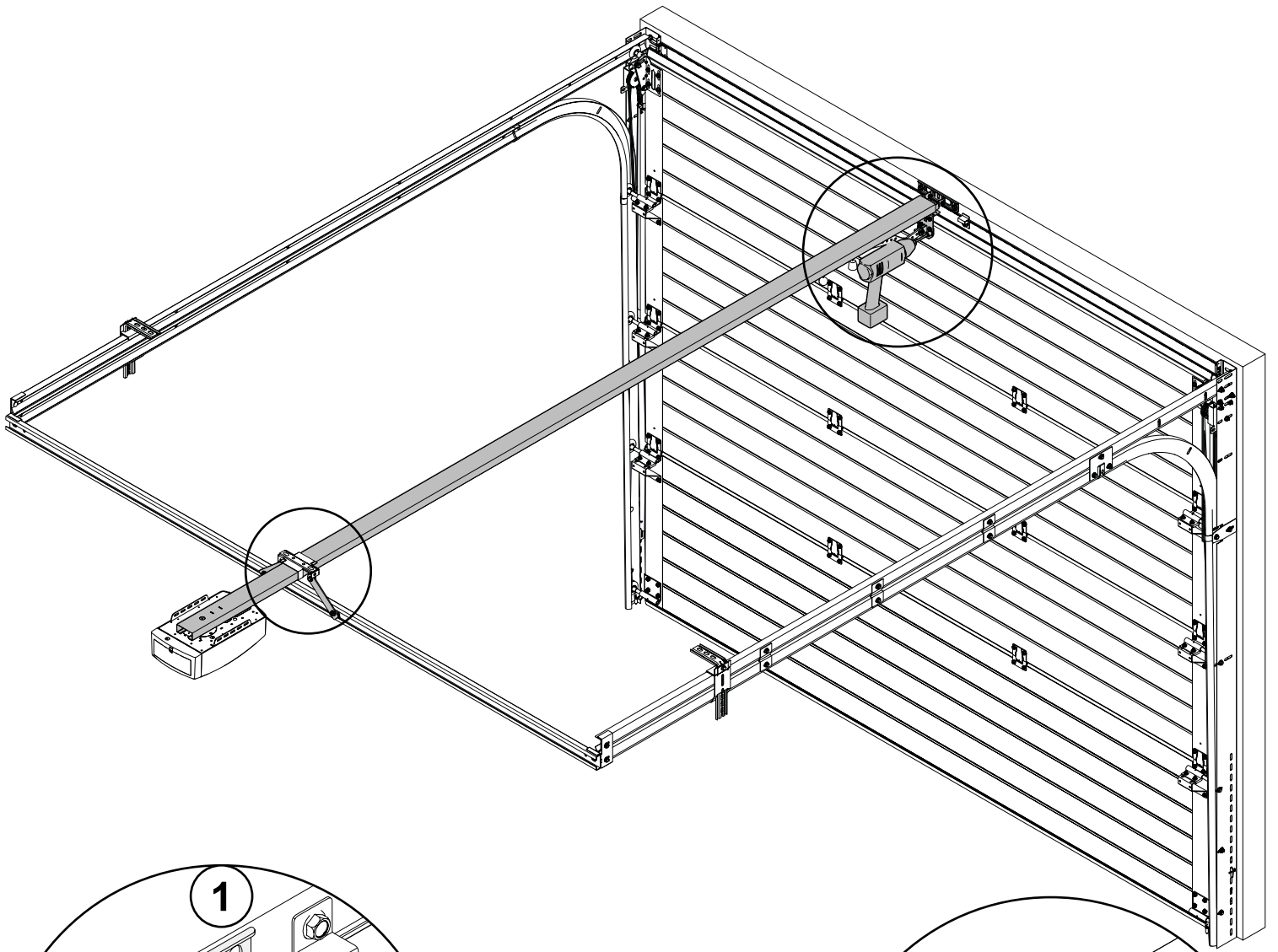

10

Optional Spring Covers

Starting at the top, hook the flat section behind the weather seal and bend the curved section behind the roller channel.

Then work the curved section behind the roller channel all the way to the floor.

Repeat on the remaining side and check the spring pulley is clear of the plastic guards.

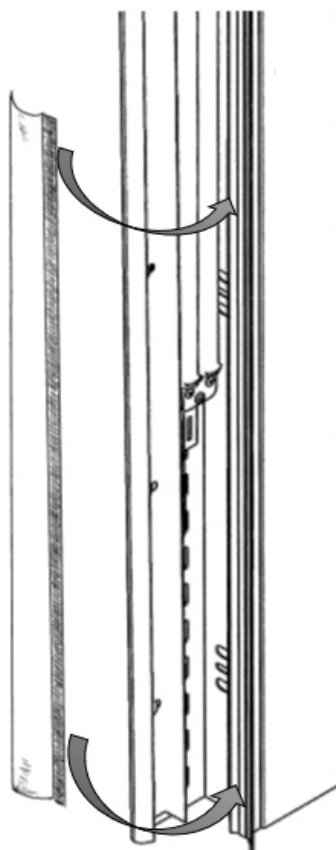

[1] Releasing the motorisation

Pull on the cord until door drive system is released.

[2] Manual manipulation of the door

This is possible as the drive system is released.

[3] Re-engaging the motorisation

Move the door manually until the drive mechanism re-locks on the transmission rail.

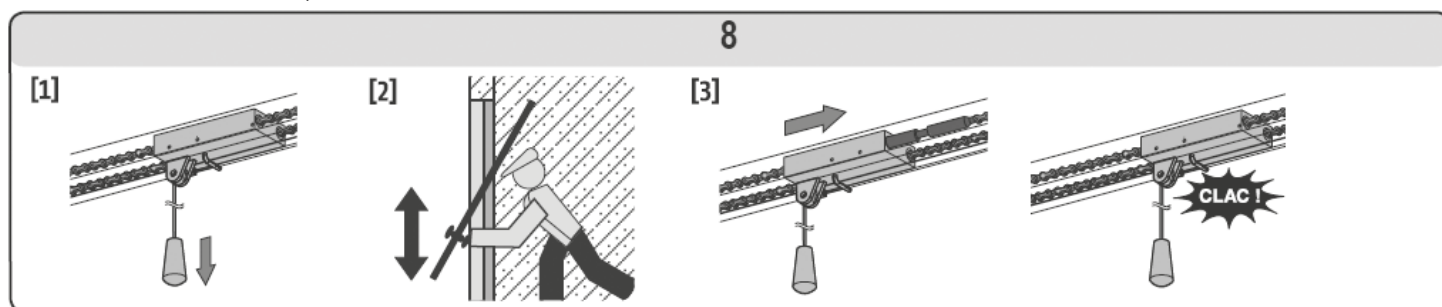

When releasing the motorisation, sudden movements may occur if the door is incorrectly balanced which may be dangerous. Only use the cord to release the motorisation. Never use the cord to manipulate the door manually. It is essential that the motorisation is re-engaged before any new commands.

